

Universal Measuring Device UMG 96S

Operating instructions

Brief instructions see last page

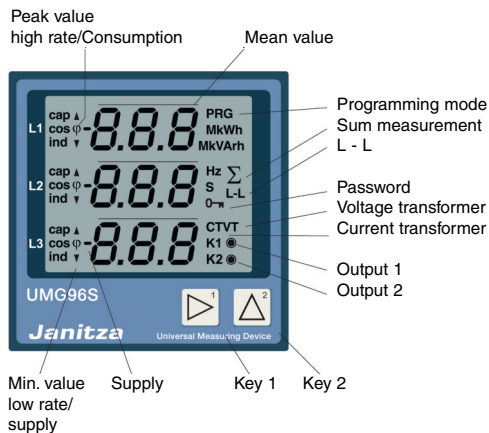

Contents

Meaning of the symbols	4	Parameters and meas. values	32
Hints for usage	4	Parameter indication at UMG96S	32
Receipt control	4	Measured value indication at UMG96S	32
Contents of delivery	5	Program parameters	33
Accessories possible	5	Mean values	34
Hints for maintenance	6	Averaging time current (Adr.057)	34
Repairing and calibration	6	Averaging time power (Adr.058)	34
Face plate	6	Averaging time voltage (Adr.073)	34
Battery	6	Minimum and maximum values	34
Waste management	6	Net frequency (Adr.063)	35
Service	6	Real energy	35
Product description	7	Current transformer (Addr. 600)	36
Intended use	7	Voltage transformer (Addr. 602)	37
Functional description	8	Harmonics (Addr.221)	38
Voltage versions	9	Measured value rotation	39
Device versions	10	Measured value indications	42
Installation	18	Indication profile (Addr. 060)	42
Mounting	18	Indication profile (Addr. 604)	43
Measurement and operation voltage	18	User password (Addr.011)	44
Current measurement	19	Delete energy (Addr.009)	44
Sum current measurement	19	Field rotation (Addr. 277)	45
Serial interfaces	20	LCD Contrast (Addr. 012)	45
Inputs and outputs	20	Time detection	46
Connection	22	Serial number (Addr. 911)	46
Putting into service	24	Software Release (Addr. 913)	47
Insert device	24	Hardware expansion (Addr. 914)	47
Connect measur. and operating voltage	24	Serial interfaces	48
Connect measurement current	25	Interface selection (Addr. 062)	48
Check phase assignment	25	Modem operation (Addr. 070)	48
Check current direction	25	MODBUS RTU	49
Check measurement	25	Realized functions	49
Check single phase power	25	RS232 interface	50
Check sum power	25	Fieldbus (RS485)	52
Removal of errors	26	Profibus DP	54
Error messages	28	Profibus profiles	56
Warnings	29	Inputs and outputs	60
Heavy errors	29	Pulse output	62
Exceeding of measuring range	29	Pulse valence	63
Usage and display	30	Digital output	66
Indication mode	30	Limit supervision	68
Programming mode	30	Analog output	70
Key functions	31	Digital input	72
		Memory	74
		Data memory (Option)	74
		Data memory (056)	74

Tables	76
Parameter list	77
Measured value list	80
Measured value displays, overview	86
Indication range and accuracy	90
Safety regulations	91
Requirements of electromagnetical compatibility	91
Technical data	92
Ambient conditions	92
Connectable wires	92
Inputs and outputs	92
Measurement	93
Serial interfaces	93
Dimension sketch	94
Connection diagrams	95
Brief instructions	96
Change current transformer	96
Call up measured values	96

All rights reserved. No part of this manual may be reproduced or duplicated without the written permission of the author. Any contraventions are punishable and will be prosecuted with all legal means.

No liability can be taken for the faultless condition of the manual or damage caused by the use of it. As failures cannot be avoided completely, we shall be very grateful for any advice. We will try to remove any failures as soon as possible. The mentioned software and hardware descriptions are registered trademarks in the most cases and are subjected to the regulations by law. All registered trademarks are property of the corresponding companies and are fully recognized by us.

Meaning of the symbols

The symbols, that were used in this manual have the following meaning:



Beware dangerous electrical voltage.



This symbol shall warn you about possible danger, that can occur while mounting, putting into service or the use of this instrument.

Hints for usage

This device may be put into service and used by qualified personnel according to the safety regulations and instructions only. Please mind the additional legal and safety regulations for the respective application.

Qualified personnel are persons, familiar with erection, mounting, putting into service and usage of the product and having the qualifications such as:

- education or instruction / entitlement to switch, release, ground or characterize current circuits and devices according to the standards of safety techniques.

- education or instruction in care and usage of suitable safety equipment according to the standards of safety techniques.



Attention!

If the instrument is not used according to the operating instructions, a safe use cannot be granted, and certain danger can be effected by the instrument.

Receipt control

In order to ensure a perfect and safe use of the device, a proper transport, expert storage, erection and mounting and careful usage and maintenance are required. When it may be supposed, that a safe operation is no longer possible, the device has to be put out of service and be protected against unintentional putting into service.

A safe operation can no longer be assumed, when the device

- shows visible damage, does not work in spite of intact net supply, has been exposed to disadvantageous conditions for a longer time (e.g. storage out of the allowed climate without adaption to the room climate, dew etc.) or transport use (e.g. falling from great height, even without visible damage).

Please test the contents of delivery for completion, before starting the installation of the device. All delivered options are listed on the delivery papers.

Contents of delivery

Number	Part.No.	Description
1	52 13 xxx ¹⁾	UMG96S
1	33 03 046	Manual, English.
1	52 07 103	2 Fixing brackets.

¹⁾ Part no. see delivery note.

Accessories possible

	Part.No.	Description
	29 01 907	Seal, 96x96
	08 01 501	PC-cable for RS232 interface, 2m



All delivered options and versions are described on the delivery papers.



This manual also describes options, which have not been delivered and, hence, do not belong to the contents of delivery.

Hints for maintenance

Before delivery the device is tested in various safety checks and marked with a seal. If the device is opened, these checks must be repeated.

There is no guarantee for devices, which are opened out of the manufacturing works.

Repairing and calibration

Maintenance and calibration can only be carried out at manufacturer's end.

Face plate

The cleaning of the front foil must be done with a soft cloth using a common cleansing agent. Acid or acidic agents may not be used for cleaning.

Battery

On the additional PCB 1 (option), there is a Lithium battery. The life expectancy of the battery at storage temperature +45°C is a minimum of 5 years. The typical life expectancy is between 8 and 10 years.

If the battery voltage is too low after net return, the display shows the warning "Err 320".

For safety reasons, the battery should be exchanged in the manufacturing works only!

Waste management

The UMG96S can be disposed and recycled as electrical waste according to the legal regulations. Please note, that the input Lithium battery must be disposed separately.

Service

If you have problems, which are not described in this manual, please ask our technical support. For further handling of your questions, please have the following on hand:

- Device description (see type plate),
- Serial number (see type plate),
- Software Release,
- Measurement and auxiliary voltage and
- Exact description of the problem.

You can contact us:

Monday to Thursday

between 07:00h and 15:00h

and Friday

between 07:00h and 12:00h

Janitza electronic GmbH

Vor dem Polstück 1

D-35633 Lahnau

Support:

Tel. (0 64 41) 9642-22

Fax (0 64 41) 9642-30

e-mail: info@janitza.de

Product description

Intended use

The UMG96S has been designed for a fixed installation in panels, measuring voltage, current, power etc. in low voltage switchgear. The measurement is laid out for three phase systems with neutral conductor (TN and TT networks).

The UMG96S gets its operating voltage from the measuring voltage and can be delivered for operating voltage of 150V and 300V. The 300V standard version, measurement and operation voltage (50Hz/60Hz) up to 300VAC against ground and 520VAC phase to phase can be connected directly. The 150V special version, measurement and operating voltage (50Hz/60Hz) up to 150VAC against ground and 240VAC phase to phase can be connected directly.

The measurement and operational voltage must be connected to the UMG96S via a separation (circuit breaker or power switch) and a fuse (2-10A) within the installation. The separation (circuit breaker or power switch) must be near to the instrument and easy to reach.

The connection of the measurement and operating voltage is carried out on the backside of the UMG96S via touch proof spring terminal. To the current inputs, either .../5A or .../1A transformers can be connected.



Attention!

The connection of the neutral conductor N is absolutely necessary.



Attention!

Measurement in systems with pulse load is not possible, because no continuous scanning of the measuring signals is carried out.



Attention!

The inputs, outputs and serial interfaces must be shielded.

Functional description

The three phase electronic measuring system detects and digitizes the true rms values of alternating voltage and current in 50/60Hz networks.

The operating voltage of the UMG96S is taken from the measuring voltage L1-N, L2-N and L3-N. Devices for the measurement in 230V/400V networks, at least one phase must be within the rated range. Instruments for measurement in 58V/100V or 63V/110V networks, at least two phases must be within the rated voltage range. Either .../5A or .../1A transformers can be connected to the current inputs. In networks with 150VAC against ground, currents up to 5A can be connected directly to the UMG96S.

Each second, one sample measurement is carried out at all current and voltage inputs. Voltage interruptions longer than one second are safely recognized. For each sample, 6 periods are scanned. From these values, the inserted microprocessor calculates the electrical quantities. The measured values can be indicated in the measured value displays. The energy and minimum and maximum values as well as the programming data are stored every 5 minutes in a non volatile memory (EEPROM).

The scanning frequency for all measuring inputs is calculated from the net frequency of phase L1. For a net frequency of 50Hz, the scanning frequency is 2.5kHz and for a net frequency of 60Hz, the scanning frequency is 3.0kHz. If voltage in L1 is smaller than 50V, the UMG96S uses the last measured net frequency for the calculation of the scanning frequency.

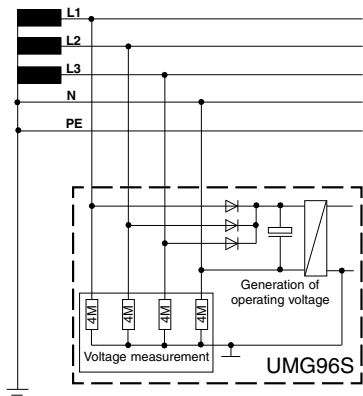

Diagr. Generation of the operating voltage, 300V standard version.

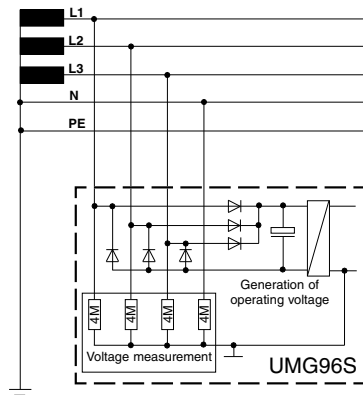

Diagr. Generation of the operating voltage, 150V special version.

Voltage versions

The UMG96S takes the measurement voltage as operating voltage and can be delivered in the versions 150V and 300V. The delivered version is indicated on the type plate of UMG96S. Please ensure, that the local net conditions match the numbers on type plate before connection.

300V standard version

In **300V standard version**, the UMG96S can measure voltage up to 300VAC against ground. At least one phase (L) of the UMG96S and the neutral N must be connected and the connected voltage must be within the measurement and operation voltage range.

The **measurement and operation voltage range** of devices without additional PCB and for devices with additional PCB 1 (analogue output) are:

Measuring range L-N	: 50 .. 300V AC
Measuring range L-L	: 87 .. 520V AC
Operating voltage range L-N	: 85 .. 300V AC

The measurement and operating voltage range for devices with additional PCB 2 (Profibus) are:

Measuring range L-N	: 50 .. 300V AC
Measuring range L-L	: 87 .. 520V AC
Operating voltage range L-N	: 140.. 300V AC

150V special version

In **150V special version**, the UMG96S can measure voltage up to 300VAC against ground. At least 2 phases (L) of the UMG96S must be connected, and the connected voltage must be within the measurement and operation voltage range.

Measuring range L-N	: 25 .. 140V AC
Measuring range L-L	: 40 .. 260V AC
Operating voltage range L-L	: 85 .. 260V AC



The operating voltage for the unit is taken from the outer conductors.



Attention!

Voltage, which is above the allowed range can damage the device.

Device versions

The UMG96S can be delivered in different versions. The customer can assign a function to the clamps 11, 12 and 13 of UMG96S.

Version 1

Version 1 contains the following functional groups:

RS485 (MODBUS RTU)

Input/Output

Pulse output 1 (W_p =real energy)

Pulse output 2 (W_q =reactive energy)

Digital output 1

Digital output 2

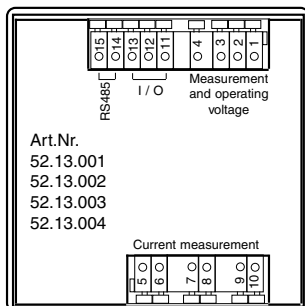

UMG96S

Basic PCB

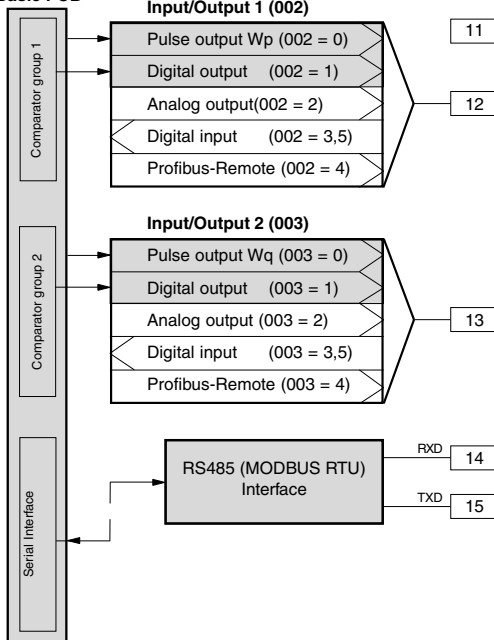

Version 2

Version 2 contains the following functional groups:

RS232 (MODBUS RTU)

RS485 (MODBUS RTU)

Input/Output

Pulse output 1 (Wp=real energy)

Pulse output 2 (Wq=reactive energy)

Digital output 1

Digital output 2

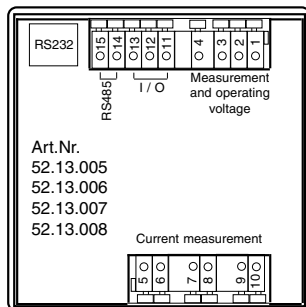

UMG96S

Basic PCB

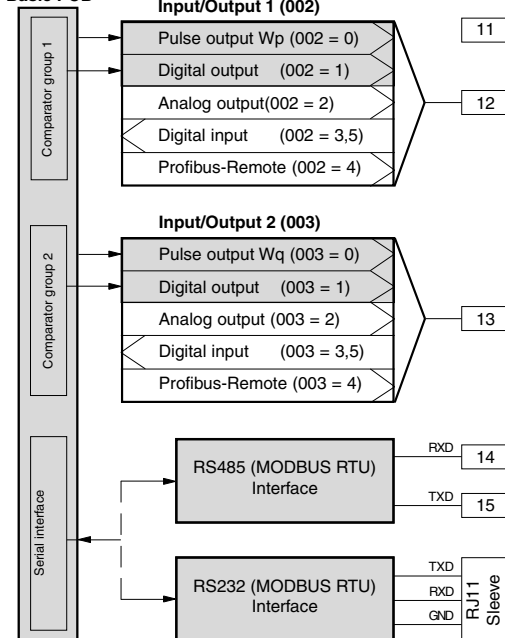

Version 3

Version 3 contains the following functional groups:

RS232 (MODBUS RTU)

RS485 (MODBUS RTU)

Input/Output

Pulse output 1 (Wp=real energy)

Pulse output 2 (Wq=reactive energy)

Digital output 1

Digital output 2

Clock with battery

Data memory

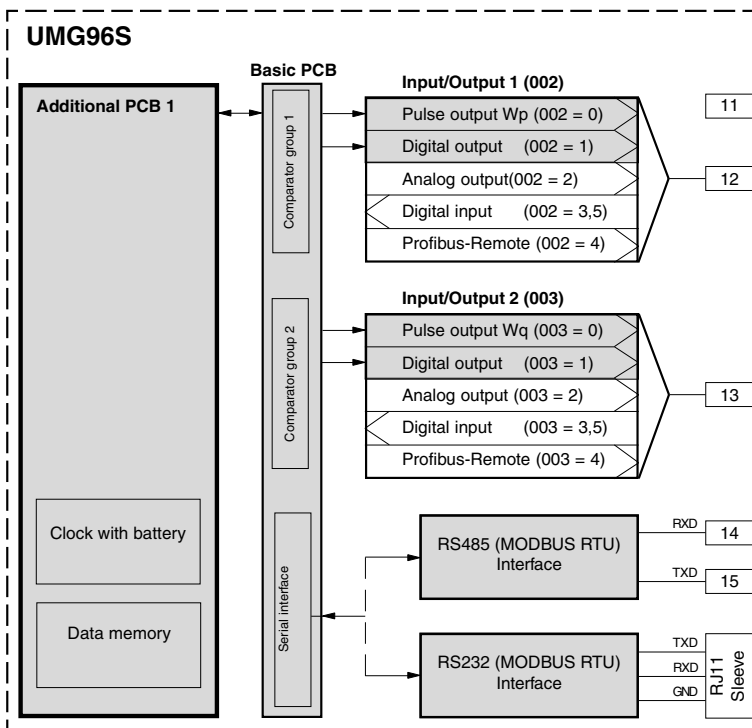
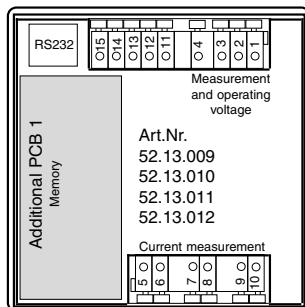

Version 4

Version 4 contains the following functional groups:

RS232 (MODBUS RTU)

RS485 (MODBUS RTU)

Input/Output

Pulse output 1 (W_p =real energy)

Pulse output 2 (W_q =reactive energy)

Digital output 1

Digital output 2

Analog output 1

Analog output 2

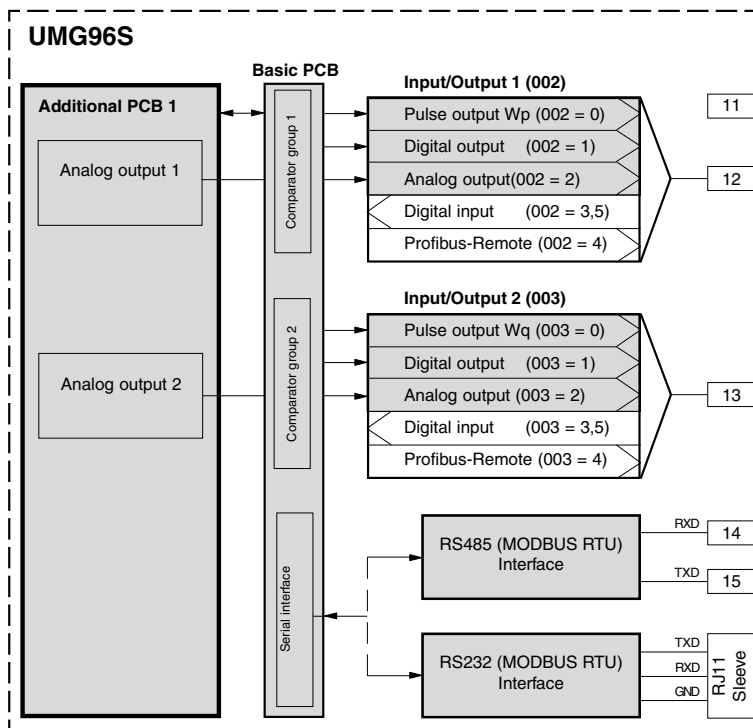
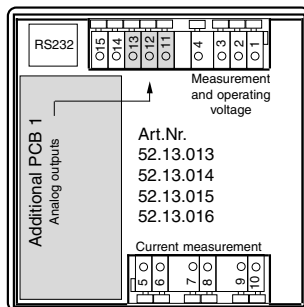

Version 5

Version 5 contains the following functional groups:

RS232 (MODBUS RTU)

RS485 (MODBUS RTU)

Input/Output

Pulse output 1 (Wp=real energy)

Pulse output 2 (Wq=reactive energy)

Digital output 1

Digital output 2

Analog output 1

Analog output 2

Clock with battery

Data memory

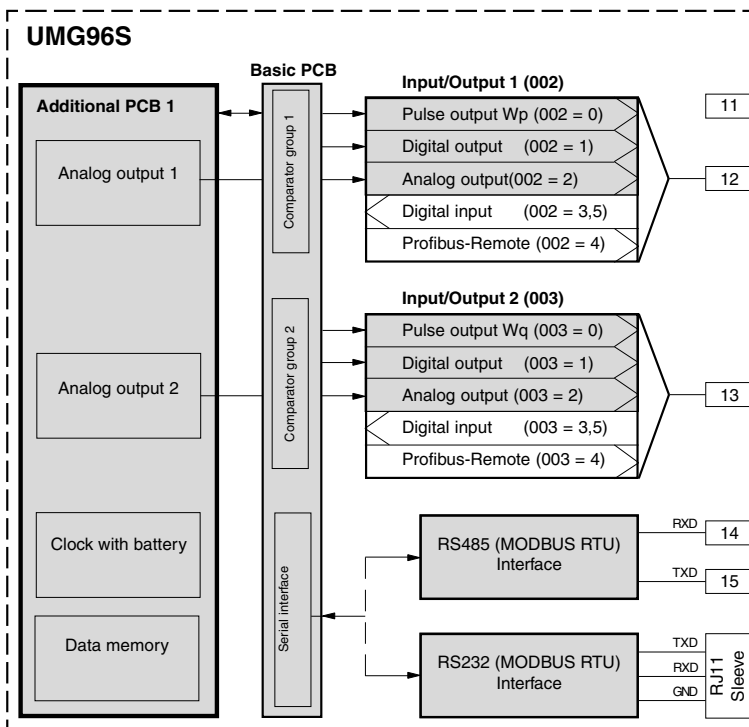
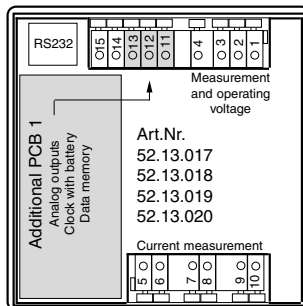

Version 6

Version 6 contains the following functional groups:

RS232 (MODBUS RTU)

RS485 (MODBUS RTU)

Input/Output

Pulse output 1 (W_p =real energy)

Pulse output 2 (W_q =reactive energy)

Digital output 1

Digital output 2

Digital input 1

Digital input 2

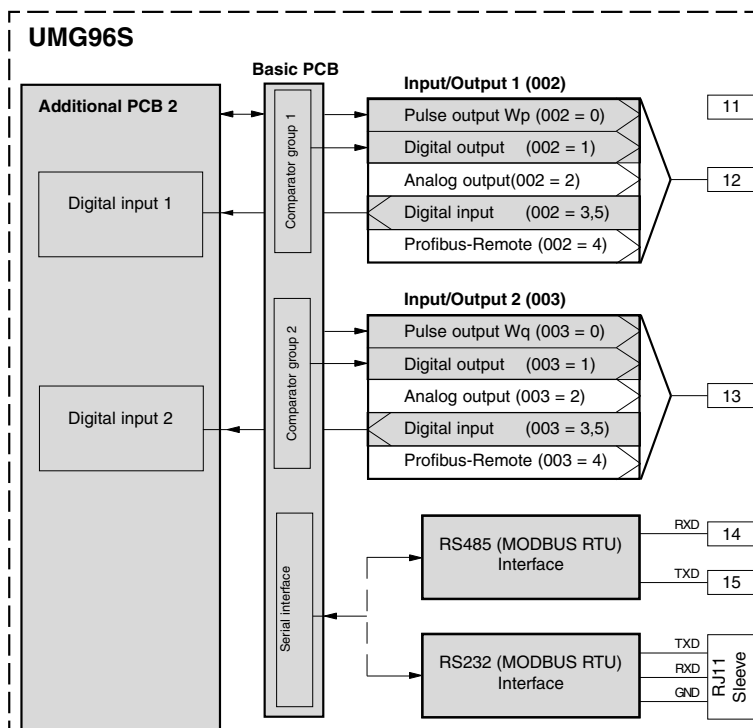
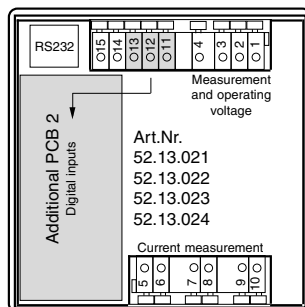

Version 7

Version 7 contains the following functional groups:

RS232 (MODBUS RTU)

RS485 (MODBUS RTU)

Profibus DP

Input/Output

Pulse output 1 (Wp=real energy)

Pulse output 2 (Wq=reactive energy)

Digital output 1

Digital output 2

Digital input 1

Digital input 2

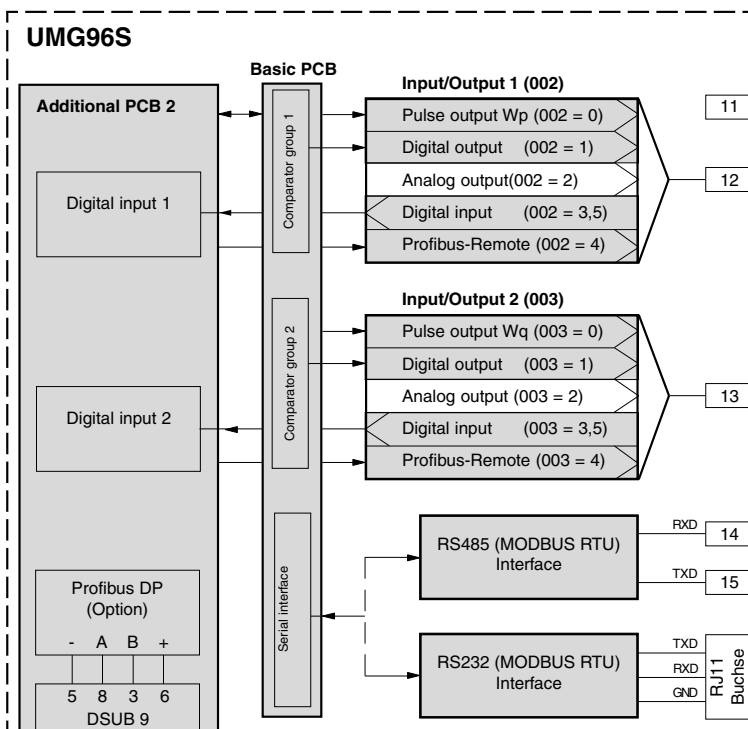
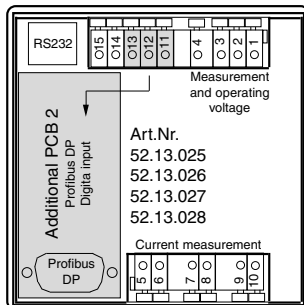

Installation

Mounting

The UMG96S is designed for a fix installation in low and medium voltage systems. The mounting position is random.

Measurement and operation voltage

The UMG96S gets its operating voltage from the measuring voltage. The measurement is designed for three phase systems with neutral conductor (TN and TT networks). The measurement and operational voltage must be connected to the UMG96S via a separation (circuit breaker or power switch) and a fuse (2-10A) within the installation. The connection of the measurement and operating voltage is carried out on the backside of the UMG96S via touch proof spring terminal.

300V standard version

At least one phase (L) of the UMG96S and the neutral N must be connected and the connected voltage must be within the measurement and operation voltage range.

The measurement and **operation voltage range** of devices without additional PCB and for devices with additional PCB 1 (analogue output) are:

L-N 85 .. 300V

L-L 148 .. 520V

The measurement and **operating voltage range** for devices with additional PCB 2 (Profibus) are:

L-N 140 .. 300V

L-L 242 .. 520V

150V special version

At least 2 phases (L) of the UMG96S must be connected, and the connected voltage must be within the measurement and operation voltage range.

The measurement and **operating voltage range** is:

L-N 50 .. 150V

L-L 85 .. 260V

- The used cables must be suitable for a rated voltage of 300VAC against ground.

- The measurement and operating voltage must be protected by a fuse. The fuse must be in the range of **2A to 10A**.

- Please provide a circuit breaker or power switch for the operating voltage.

- The switch must be near the UMG96S and easy to reach.

- The switch must be marked as a separation for this instrument.



Attention!

The limits, mentioned under "technical data" may not be exceeded, even not during checking or putting into service of UMG96S.



Attention!

Before connecting voltage, the device should be deposited in the proposed installation room for at least 2 hours, in order to create a temperature equalization and avoid humidity or dew within the instrument.

Current measurement

The current measurement is carried out via current transformers of either $..5A$ or $../1A$. If the current must be measured by an Amperemeter additionally, it must be connected in series to the UMG96S.

In networks with voltage up to 150VAC against ground, currents up to 5A can be connected directly to the UMG96S.

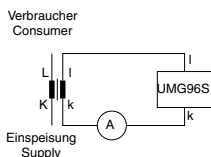

Sum current measurement

If the current measurement is carried out via two current transformers and a sum current transformer, the total transformer ratio must be programmed at UMG96S.

Example: Sum current transformer

A current measurement is carried out via one ct with a ratio of $1000/5A$ and one ct with a ratio of $1000/5A$. The current measurement is carried out via a sum current transformer $5+5/5A$.

The UMG96S must be programmed as follows:

Primary current: $1000A + 1000A = 2000A$

Secondary current: **5A**

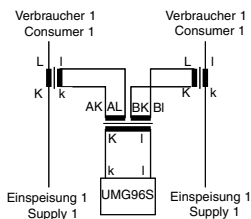

Attention!

The secondary connections of the current transformer must be short-circuited, before the wires that lead to the device are interrupted!

If a testing switch is available, which short-circuits the secondaries of the cts automatically, it is sufficient to set it into position "check", provided that the short-circuiters have been checked before.

Serial interfaces

Depending on the version the UMG96S may have up to three serial interfaces. The serial interfaces are not separated galvanically.

The RS232 and RS485 **cannot** be operated at the same time!

If both interfaces are connected, the device recognizes by the signal level, if an instrument is connected to the RS232. The data transmission is carried out via RS232 only.

If no device is recognized at RS232, data transmission is active on RS485 interface.



The cable for serial data transmission must be performed in a shielded way, if the cable length is more but 30m or the cable leaves a building.



Attention!

Real energy W_p is firmly assigned to puls output 1.

Reactive energy W_q is firmly assigned to puls output 2.

Inputs and outputs

The UMG96S offers the possibility of assigning different functions to the outputs of the different versions (options).

Terminal 12, for example, can have the function "pulse output" and terminal 13 can have the function "digital input". Please note, that both circuits have a common supply +24VDC, terminal 11.

Only one function can be assigned to each terminal 12 and 13.

Input/Output 1

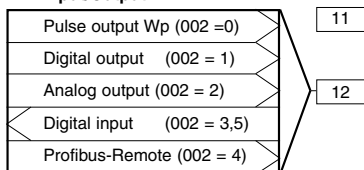

Input/Output 2

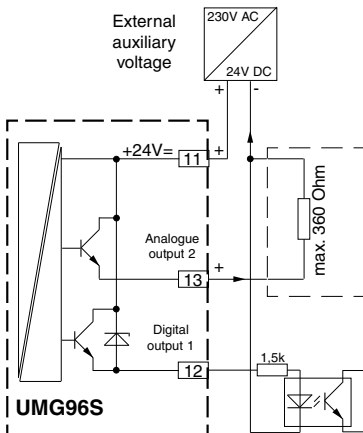
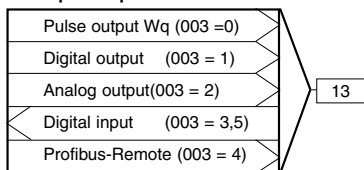

Diagr.: UMG 96S with one analogue and one digital output as pulse output for real energy.

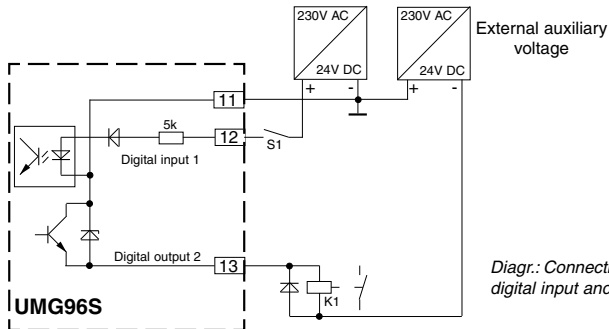

Diagr.: Connection example for one digital input and one digital output

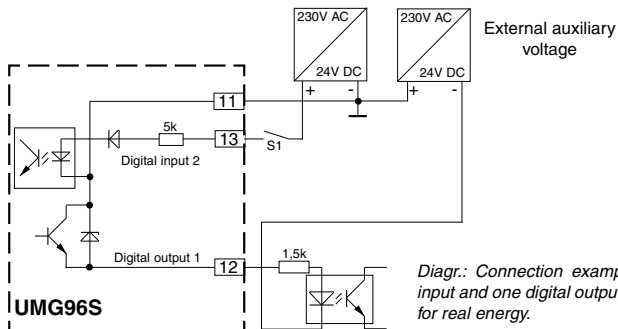

Diagr.: Connection example for one digital input and one digital output 1 as pulse output for real energy.

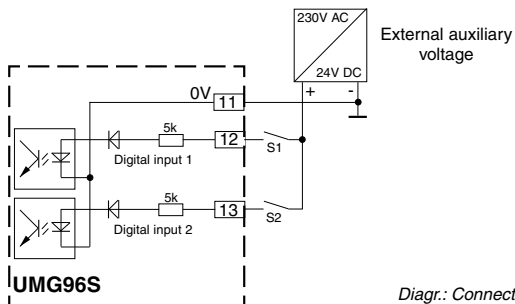

Diagr.: Connection example for digital inputs

Connection

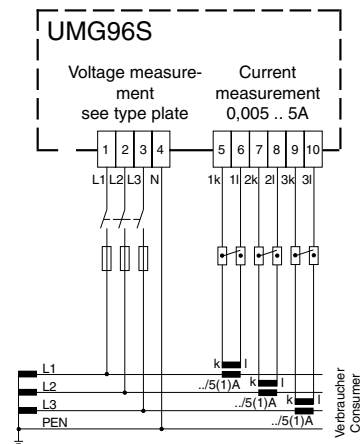

Diagr.: Connection example 1
Four wire measurement with three current transformers.

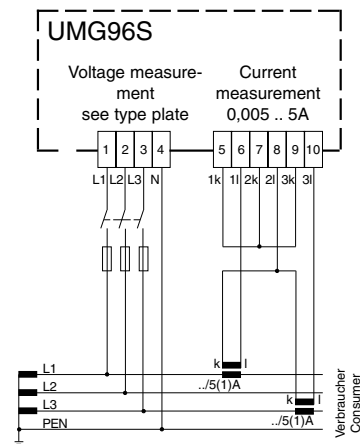

Diagr.: Connection example 2
Four wire measurement with two current transformers.

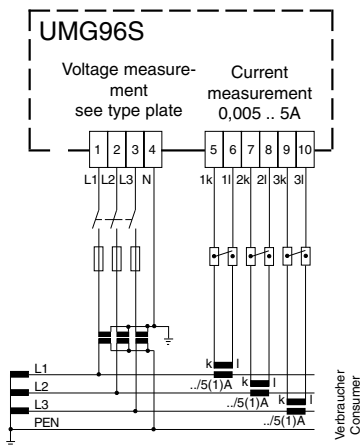

Diagr.: Connection example 3
Measurement with three voltage transformers and three current transformers.

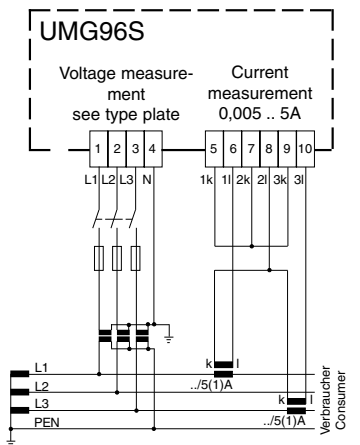

Diagr.: Connection example 4
Measurement with three voltage transformers and two current transformers.

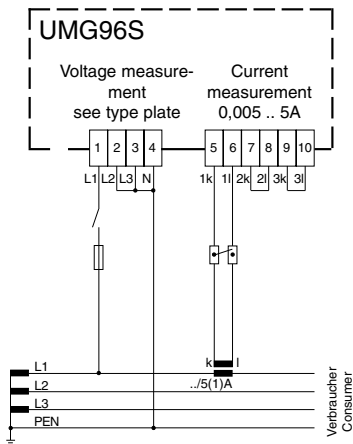

Diagr.: Connection example 5
Single phase measurement.

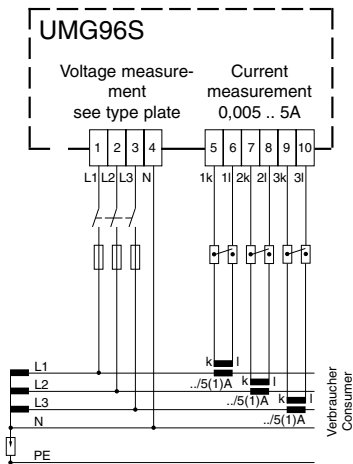

Diagr.: Connection example 7
Measurement in IT network via three current transformers.

Putting into service

The installation of the UMG96S should be carried out as follows:

Insert device

The UMG96S is designed for mounting in low voltage distributions, which can lead to overvoltage of the class III at maximum.

The mounting position is random. For the installation in face plates or panel doors, the delivered fixing brackets must be used.

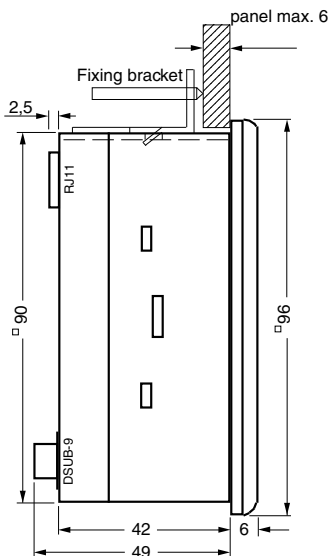

Cut out: $92^{+0,8} \times 92^{+0,8}$ mm

Connect measurement and operating voltage

The dimension of the measurement and operating voltage is indicated on the type plate.



Measurement and operating voltage, which do not correspond to the numbers on type plate can lead to malfunctions or damage of the instrument.

The wires for the measuring voltage of the UMG96S must be suitable for voltage up to 300VAC against ground or 520VAC phase to phase.

After connection of the mentioned measurement and operating voltage to the UMG96S, all segments of the display appear. About two seconds later, the UMG96S changes to the first measured value indication.

If no indication appears, please check, if the operating voltage is within the rated range.

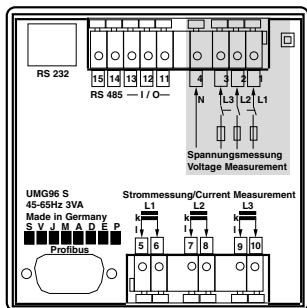

Programm current and voltage transformer

When the device is delivered, a current transformer of 5/5A is set.

The voltage transformer ratio may only be changed, when a voltage transformer is connected.

While using voltage transformers, the given measurement and operating voltage must match the type plate of the UMG96S!

Connect measurement current

The UMG96S is designed for the connection of $\dots/1A$ and $\dots/5A$ current transformers.

Only alternating currents can be measured, no direct currents



Current transformer terminals must be earthed on the secondary.

Current transformers, which do not carry load on the secondary, can lead live voltage and must be short-circuited.

Please connect the current inputs one after the other and compare the indicated current with the real current. Please remember, that the ct ratio is set to 5/5A and must be adapted to the used cts.

If the current transformer is short-circuited on the secondary, the UMG96S must indicate zero A in the corresponding outer conductor.

The current, indicated by UMG96S must correspond to the input current with respect to the current transformer.

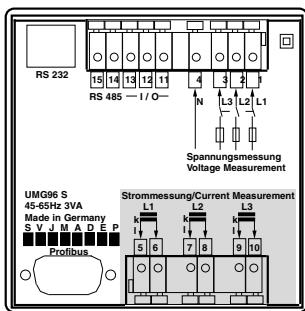

Check phase assignment

The assignment outer conductor to current transformer is correct, when the indicated current in UMG96S gets 0A while short-circuiting the secondary of the current transformer.

Check current direction

Short-circuit two current transformers. The remaining phase must display real power as:

(+) for consumption of real power or (-) for supply of real power (generator).

If no real power is indicated, the assignment of voltage to current may be false.

Check measurement

If all voltage and current inputs are connected correctly, the single phase and sum power must be calculated and indicated correctly.

Check single phase power

If a current transformer is assigned to the wrong outer conductor, the corresponding power is measured incorrectly.

The assignment of the outer conductor and ct at UMG96S is correct, when there is no voltage between outer conductor and the corresponding ct (primary).

To ensure the outer conductor is assigned to the right ct, the ct can be short-circuited at the secondary. The UMG96S must indicate the corresponding apparent power in this phase with zero.

If the apparent power is indicated correctly, but the real power is indicated negatively, the ct terminal has been exchanged or power is supplied to the energy supplier (generator).

Check sum power

If all voltage, current and power are indicated correctly, the sum power must be indicated correctly as well. As confirmation, please compare the indicated sum power of UMG96S with other meters, that might be available.

Removal of errors

Fault	Possible reason	Remedy
Display dark.	Fuse may have released. Device defective.	Renew fuse. Send device to the manufacturer for repair.
A measured value display cannot be retrieved.	The display has been deleted from measured value selection.	The desired display must be added into the measured value selection.
No current indicated.	The corresponding measuring voltage has not been connected.	Connect the corresponding measured voltage.
Current too small.	Current measurement in wrong phase.	Check and correct connection.
Wrong current.	Current measurement in wrong phase. Current transformer ratio badly programmed.	Check and correct connection. Read CT ratio on CT and program correctly.
	Exceeding of measuring range.	Select and program CT with higher ratio.
	The maximum current input is exceeded by harmonics.	Select and program CT with higher ratio. Attention! Please ensure, that the measuring inputs are not overloaded.
	The current at measuring input has been underscored.	Select and program CT with lower ratio.
Wrong voltage L-N.	Measurement in wrong phase	Check and correct connection.
	Voltage transformer wrongly programmed.	Read voltage transformer ratio at voltage transformer and program accordingly.
Voltage L-L too small / too big.	Outer conductors exchanged.	Check and correct connection. Attention! Please ensure, that the measuring inputs are not overloaded.
	Wrong connection.	Check and correct connection.

Fault	Possible reason	Remedy
Phase shift ind/kap.	Current path assigned to the wrong voltage path.	Check and correct connection.
Programming data are lost.	The device was exposed to higher electromagnetic interference than indicated in the technical data.	Improve external protection measures like shielding, filtering, earth or local separation.
Real power too small / too big.	CT ratio badly programmed. Current path assigned to wrong voltage path.	Read and program CT ratio. Check and correct connection.
Real power cons./ supply exchanged.	At least one CT connection exchanged. Current path assigned to the wrong voltage path.	Check and correct connection. Check and correct connection.
An output does not react.	Output badly programmed. Output badly connected.	Check and correct programming. Check and correct connection.
"EEE" in Display	See error messages.	
The device does not work properly despite the above.	Device defective.	Please send the device to the manufacturer with a detailed description of the error.

Error messages

The UMG96S shows three different error messages:

- **Warnings,**
- **Heavy errors** and
- **Exceeding of measuring range.**

For warnings and heavy errors, the symbol "EEE" and a corresponding error number is indicated.

Symbol for error message

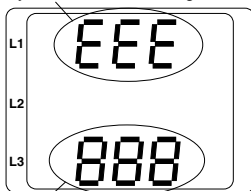

Error number

Example: Error number 911

The UMG96S displays error number 911.

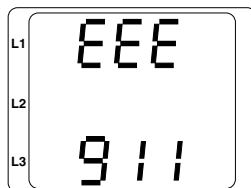

The error number is assembled by the heavy error 910 and the internal reason of error 0x01. In this example an error occurred while reading the calibration data from EEPROM. The device must be sent to the manufacturer.

The three digit error number consists of the description of the error and a possible reason for the error, provided that UMG96S can detect it.

Symbol for error message

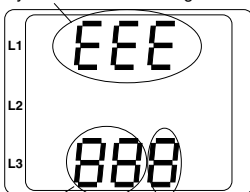

Reason of error

Error description

Warnings

Warnings are not heavy errors and can be confirmed by the keys 1 or 2. The retrieving and indication of measured values continues. This error will be displayed with every voltage return. The instrument should be sent to the manufacturer for checking.

Error	Description
100	Error while writing programming data.
110	Error while writing a counter.
120	Error while writing maximum values.
220	Error while reading counters.
230	Error while reading maximum values.
300	Clock out of range.
310	Data memory not found.
320	Battery low or clock not set.
400	Profibus not found.
500	The net frequency could not be detected. The voltage in phase 1 is smaller than 50V. The basic frequency is out of range 45 .. 65Hz.

Heavy errors

The device must be sent to the manufacturer for checking.

Error	Description
800	Error while writing a block.
810	Error while writing calibration.
900	Error while reading a block.
910	Error while reading calibration.

Internal reasons of errors

In some cases, the UMG96S can detect an internal error and indicate the following error codes. The device must be sent to the manufacturer for checking.

Error	Reason for Error
0x01	EEPROM does not answer
0x02	Exceeding of address range.
0x04	Checksum error.
0x08	Error in internal I2C-Bus.

Exceeding of measuring range

Exceedings of measuring range are indicated as long as they occur and cannot be confirmed. An exceeding occurs, when one or more current or voltage input is outside the specified range. With the keys "upwards" the phase, in which the exceeding occurred, is marked. The symbols "V" and "A" indicate, if the exceeding was caused by voltage or current.

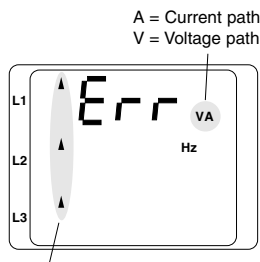

Exceeding of measuring range
in phase L1/L2/L3



Attention!

Voltage and current out of the specified range can damage the instrument.

Usage and display

The usage of the UMG96S is carried out via the keys 1 and 2. Measured values and programming data are indicated on a LCD display. The indication mode and programming mode can be distinguished. It is possible to avoid an unintentional changing of programming data by entering a password.

Indication mode

In indication mode, please scroll through the programmed measured values by using the keys 1 and 2. When the device is delivered, all measured value indications of profile 1 can be retrieved. For each measured value, up to three measured values are indicated. The measured value rotation can display selected measured value indications one after the other with a selectable changing time.

Programming mode

In programming mode the necessary settings of the UMG96S can be indicated and changed. Pressing key 1 and 2 simultaneously for about 1 second, you reach programming mode via password request. If no password was entered, you directly reach programming mode. Programming mode is marked by the text „PRG“ in the display.

Using key 2, you can change over between the following menus:

- Current transformer,
- Voltage transformer,
- Parameter list.

If you are in programming mode, and no key was pressed for about 60 seconds, or key 1 and 2 are pressed simultaneously, the UMG96S returns to indication mode.

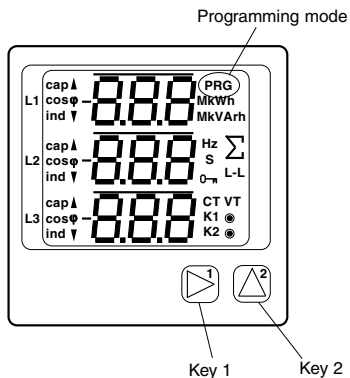

Key functions

	Indication mode	Password	Programming mode
Change mode	<p>simultaneously</p>		
Scroll			
Programming			<p>Programming Menu Confirm selection</p> <p>8 Short number +1 Long number -1</p> <p>888 short value *10 <i>(move decimal point to the right)</i> long value /10 <i>(move decimal point to the left)</i></p> <p>flashing</p>

Parameters and measured values

All necessary parameters for the use of UMG96S, such as ct data as well as all measured values are deposited in a list. Each parameter and each measured value has a 3 digit address. It is possible to retrieve the contents of most of the addresses via serial interface and via the keys of UMG96S.

Selected measured values are summarized in measured value profiles and can be indicated in indication mode while using the keys 1 and 2.

You can have access to the most parameters in programming mode. One part of the parameters, for example the software release, can be read only. The actual measured value profile, the rotation profile as well as date and time can be read and changed via the interfaces RS232 or RS485 only.

Current and voltage transformer

The primary and secondary values for current and voltage cannot be entered in the parameter list directly.

Current and voltage transformer are programmed as written in the brief instructions on the last page of this manual. Afterwards the programmed values are mentioned in the parameter list and can be read.

Parameter indication at UMG96S

In this example, the contents of address "000" is indicated by the value "001" on display of UMG96S. The UMG96S has device address 1.

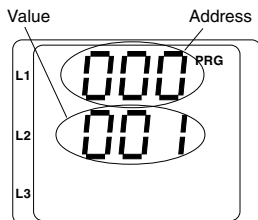

Measured value indication at UMG96S

In this example, the voltage L-N is indicated with 230V on display of UMG96S. The transistor outputs K1 and K2 are active, current can flow.

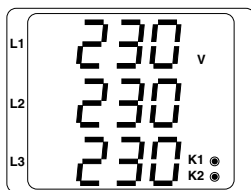

Attention!

The set parameters are not checked to be plausible!

Program parameters

Press both keys simultaneously for about 1 second.

If a user password was programmed, the password request appears with "000".

The first number of the user password flashes and can be changed with key 2. Pressing key 1, the next number is selected and flashes.

If the right combination was entered or no user password was programmed, you reach programming mode.

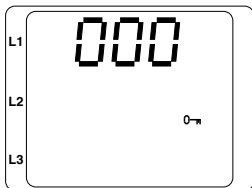

In programming mode the menu for the current transformer appears first.

With key 2, move to programming menu for voltage transformer and parameter list.

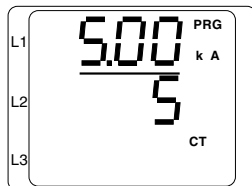

The parameters for current and voltage transformer can only be read at UMG96S.

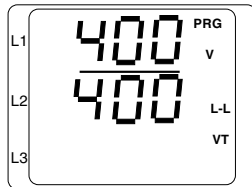

Change a parameter at parameter list.

Confirm selection with key 1.

The last selected address and the corresponding value is indicated.

The first number of the address is flashing.

Select address.

Select address with key 1 and change with key 2.

Change value.

The desired address is set.

Select a number of the value with key 1 and change with key 2.

Leave programming

Press both keys simultaneously for about 1 second.

Address

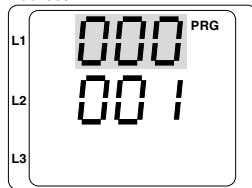

value



Mean values

For current and power values, mean values are generated over an adjustable time. The mean values are marked by a horizontal bar above the measured value.

Averaging time current (Adr.057)

The averaging times for power and current mean values are programmed separately from a list of seven preset averaging times.

Averaging time power (Adr.058)

The averaging times for the power mean values are programmed separately.

Averaging time voltage (Adr.073)

Number	Averaging times/ Seconds
0	5
1	10
2	30
3	60
4	300
5	480
6	900 (Presetting)

Method of taking the mean

The used exponential method for taking the mean reaches at least 95% of the measured value after the set averaging time.

$$M_{\text{mean}} = \text{Mean} - 1 + (M_{\text{meas}} - M_{\text{mean}} - 1) / N$$

M_{mean} = Displayed mean value.

M_{meas} = Measured value.

n = Consecutively numbered measured value.

N = Number of measured values, that shall be used for taking the mean.

Minimum and maximum values

Once per second, all measured values are measured and calculated. For the most measured values, the minimum and maximum values are determined.

The minimum value is the lowest value, which was measured since the last deletion. The maximum value is the highest measured value, which was measured since the last deletion. All minimum and maximum values are compared to the corresponding measured values, and overwritten while underscoring or exceeding.

The minimum and maximum values are stored every five minutes in an EEPROM without date and time. In case of a breakdown of the operating voltage, only the last minimum and maximum values of the last five minutes get lost.

Delete minimum and maximum values (Adr.008)

If a "001" is written into address 008, all minimum and maximum values are deleted simultaneously.

An exception is the maximum value of the current mean value. The maximum value of the current mean value can also be deleted directly in indication menu by long pressing key 2.

Prior to commissioning potential production dependant contents of the energy counter and min/max values have to be deleted.

Net frequency (Adr.063)

The net frequency is detected from the measuring voltage of phase 1. The scanning frequency for the voltage and current inputs is calculated from the net frequency.

At measurements with very disturbed voltage, the frequency cannot be detected accurate enough. Voltage disturbances occur at consumers, which are operated with phase angle modulated power.

For measurements, which show strong distortion, the corresponding net frequency should be fixed. Distortion of the current have no influence on frequency detection.

If the measuring voltage is missing, no net frequency can be detected, and no scanning frequency can be calculated. The error message "500" is displayed and can be confirmed. Voltage, current and all resulting values are not calculated and indicated by zero.

If the current shall be measured without measuring frequency, the net frequency must be selected as a fix frequency at UMG96S.

The determination of the net frequency can be carried out automatically or programmed fixly. The following settings for the destination of the net frequency are at your disposal:

- 0 - Automatic frequency detection
- 1 - Fix frequency 50Hz
- 2 - Fix frequency 60Hz

Real energy

The UMG96S has 7 energy meters: Three real energy meters, three reactive energy meter and one apperend energie meter.

Adr.	Bezeichnung
416	Sum real energie, without reverse running stop.
418	Sum reactive energie, inductive.
422	Sum real energie, cosumption or HT.
424	Sum real energie, supply or NT.
426	Sum reactive energie, cap./HT(ind).
428	Sum reactive energie, ind./NT(ind).
430	Sum apperend energie.

The changeover of low and high tariff is done via digital inputs (option).

Decimal points

The decimal points, indicated for energy, depend on the transformer ratio.

Transformer ratio: $v = vi \times v$

Transformer ratio	Indication format
$v > 100$	### ## #
$v > 10 \dots 100$	### ## #.#
$v \leq 10$	### ## #.##

Sum real energy

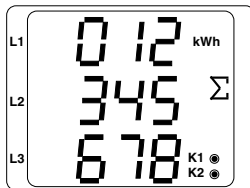

Sum real energy HT/consumption

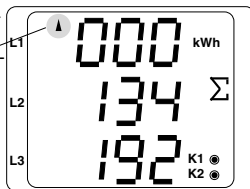

Current transformer (Addr. 600)

Either 1A or 5A transformers secondaries can be connected to UMG96S optionally.

When the device is delivered, a CT of 5A/5A is programmed. In programming mode, the current transformer is shown by the symbol „CT“.

Example: Sum current transformer

A current measurement is carried out via one transformer with a ration of 1000/5A and one current transformer with a ratio of 1000/5A. The sum measurement is carried out by a sum current transformer 5+5/5A.

The UMG96S must be programmed as follows:

Primary: $1000A + 1000A = 2000A$

Secondary: **5A**

Programming

In programming mode, please scroll to the setting of current transformer with key 2. Confirm with key 1.

The first number of the primary is flashing and can be changed with key 2. Confirming with key 1, the next number is selected and flashes.

If the complete number is flashing, the decimal point can be moved.

Pressing key 2 shortly, the decimal point moves to the right.

Pressing key 2 for a long time, the decimal point moves to the left.

If no number is flashing, scroll to the indication of the voltage transformer with key 2.

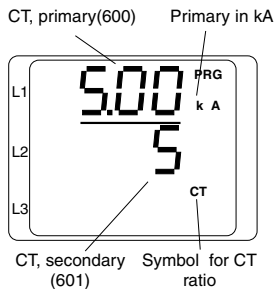

Voltage transformer (Addr. 602)

As secondary and primary voltage, the numbers in the display are given in **line to line voltage (L-L)**. The transformer ratio is calculated by the primary and secondary voltage.

When the device is delivered, a ratio of 1:1 is set.

300V Standard version: 400V/400V (148..520V)

150V Special version: 100V/100V (85..260V)

For the 300V standard version, voltage transformers with a secondary in the range of 148V to 520V can be connected.

In programming mode, the VT ratio is indicated by the symbol „VT“.

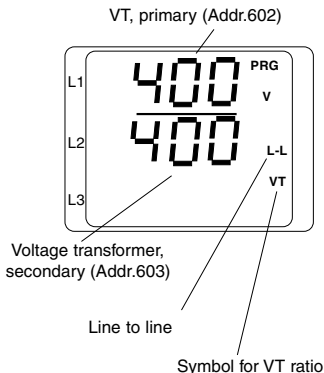

Programming

In programming mode, please scroll to the setting of the voltage transformer with key 2. Confirm with key 1.

The first number of the primary is flashing and can be changed with key 2. Confirming with key 1, the next number is selected and flashes.

If the complete number is flashing, the decimal point can be moved.

If no number is flashing, scroll to the indication of the programming of outputs with key 2.

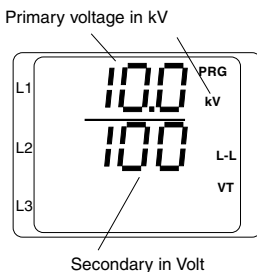

Harmonics (Addr.221)

Harmonics are the integer multiple of the fundamental wave. The UMG96S measures the fundamental of voltage in the range of 45 to 65 Hz. The calculated harmonic voltage and current is related to this fundamental. For strongly distorted voltage, the fundamental cannot be determined accurate enough. In order to be able to calculate the harmonics nevertheless, a fix fundamental of 50 or 60Hz can be selected. Please see chapter "scanning frequency". The UMG96S calculates harmonics up to the 15th multiple of the fundamental.

Partial harmonics (Addr.221)

In the further description, the single harmonics are described as partial harmonics. The partial harmonics of the current are given in Ampere and the partial harmonics of voltage are given in Volt.

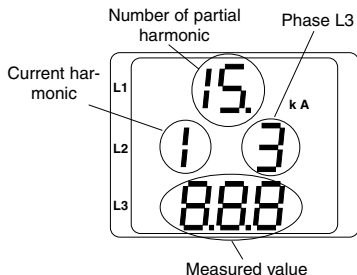

In this example, the 15th harmonic of current in L3 is indicated.

Total harmonic distortion factor THD (Addr.269)

The total harmonic distortion factor, which is calculated by UMG96S for current and voltage, represents the ratio of the effective value of the distorted quantity compared to the effective value of the measured quantity. The total harmonic distortion factor is given in per cent: Total harmonic distortion of current THDI:

$$THD_I = \frac{\sqrt{I^2 - I_1^2}}{I} \times 100\%$$

Total harmonic distortion of voltage THDU:

$$THD_U = \frac{\sqrt{U^2 - U_1^2}}{U} \times 100\%$$

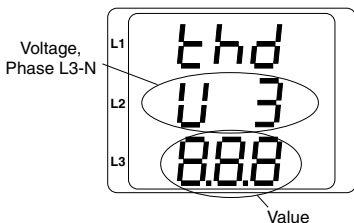

In this example, the total harmonic distortion factor **THD** of voltage is indicated for phase L3.

Measured value rotation

All measured values are calculated once per second and can be called up on the display. Two methods are available for calling up the measured values:

- The automatic changing of measured values, which is described as measured value rotation.
- The selection of a measured value via the keys 1 and 2 from a selected indication profile.

Both methods are available simultaneously. The measured value rotation is active, if at least one measured value indication is selected with a changing time longer than 0 seconds.

If a key is pressed, please scroll through the measured value indications of the selected profile. If no key was pressed for about 60 seconds, measured value rotation is started, and the selected measured values are indicated cyclically one after the other.

Changing time (Addr.059)

Setting range: 0 .. 60 seconds

If 0 seconds are set, no changing of the indications is effected.

The changing time is valid for all measured value rotation profiles.

Measured value rotation profiles (Addr.061)

Setting range: 0 .. 3

0 - Rotation profile No.0, fix.

1 - Rotation profile No.1, fix.

2 - Rotation profile No.2, fix.

3 - Rotation profile No.3, specifically. This profile can be programmed by the software GridVis only.

Rotation profile No.0

(See page 86 to 89)

	A	B	C	D	E	F	G	H
01	x		x	x				
02	x		x	x				
03	x	x	x	x				
04	x	x	x	x				
05	x	x	x					
06	x	x	x	x				
07	x	x	x					
08	x	x	x					
09	x	x	x					
10	x	x	x					
11	x	x	x					
12	x	x	x					
13	x	x	x					
14	x	x	x					
15	x							
16	x	x						
17	x							
18	x	x	x	x				
19	x	x	x					
20	x	x	x	x	x	x	x	x
21	x	x	x	x	x	x	x	x
22	x	x	x	x	x	x	x	x
23	x	x	x	x	x	x	x	x
24	x	x	x	x	x	x	x	x
25	x	x	x	x	x	x	x	x
26	x	x	x	x	x	x	x	x
27	x	x	x	x	x	x	x	x
28	x	x	x	x	x	x	x	x
29	x	x	x	x	x	x	x	x
30	x	x	x	x	x	x	x	x
31	x	x	x	x	x	x	x	x
32	x	x	x	x	x	x	x	x

In the overview for the measured value indications, "A01" corresponds to the indication of voltage L-N.

Rotation profile No.1
(See page 86 to 89)

	A	B	C	D	E	F	G	H
01	x		x	x				
02	x		x	x				
03	x	x	x	x				
04	x	x	x	x				
05	x	x	x					
06	x	x	x	x				
07	x	x	x					
08	x	x	x					
09	x	x	x					
10	x	x	x					
11	x	x	x					
12	x	x	x					
13	x	x	x					
14	x	x	x					
15	x							
16	x	x						
17	x							
18	x	x	x	x				
19	x	x	x					
20	x	x	x	x	x	x	x	
21	x	x	x	x	x	x	x	x
22	x	x	x	x	x	x	x	x
23	x	x	x	x	x	x	x	x
24	x	x	x	x	x	x	x	x
25	x	x	x	x	x	x	x	x
26	x	x	x	x	x	x	x	x
27	x	x	x	x	x	x	x	x
28	x	x	x	x	x	x	x	x
29	x	x	x	x	x	x	x	x
30	x	x	x	x	x	x	x	x
31	x	x	x	x	x	x	x	x
32	x	x	x	x	x	x	x	x

Rotation profile No.2
(See page 86 to 89)

	A	B	C	D	E	F	G	H
01	x		x	x				
02	x		x	x				
03	x	x	x	x				
04	x	x	x	x				
05	x	x	x					
06	x	x	x	x				
07	x	x	x					
08	x	x	x					
09	x	x	x					
10	x	x	x					
11	x	x	x					
12	x	x	x					
13	x	x	x					
14	x	x	x					
15	x							
16	x	x						
17	x							
18	x	x	x	x				
19	x	x	x					
20	x	x	x	x	x	x	x	x
21	x	x	x	x	x	x	x	x
22	x	x	x	x	x	x	x	x
23	x	x	x	x	x	x	x	x
24	x	x	x	x	x	x	x	x
25	x	x	x	x	x	x	x	x
26	x	x	x	x	x	x	x	x
27	x	x	x	x	x	x	x	x
28	x	x	x	x	x	x	x	x
29	x	x	x	x	x	x	x	x
30	x	x	x	x	x	x	x	x
31	x	x	x	x	x	x	x	x
32	x	x	x	x	x	x	x	x

Rotation profile No.3
(Specifically, can only be programmed by PC!)

	A	B	C	D	E	F	G	H
01	x		x	x				
02	x		x	x				
03	x	x	x	x				
04	x	x	x	x				
05	x	x	x					
06	x	x	x	x				
07	x	x	x					
08	x	x	x					
09	x	x	x					
10	x	x	x					
11	x	x	x					
12	x	x	x					
13	x	x	x					
14	x	x	x					
15	x							
16	x	x						
17	x							
18	x	x	x	x				
19	x	x	x					
20	x	x	x	x	x	x	x	x
21	x	x	x	x	x	x	x	x
22	x	x	x	x	x	x	x	x
23	x	x	x	x	x	x	x	x
24	x	x	x	x	x	x	x	x
25	x	x	x	x	x	x	x	x
26	x	x	x	x	x	x	x	x
27	x	x	x	x	x	x	x	x
28	x	x	x	x	x	x	x	x
29	x	x	x	x	x	x	x	x
30	x	x	x	x	x	x	x	x
31	x	x	x	x	x	x	x	x
32	x	x	x	x	x	x	x	x

Rotation profile No.3 (Addr.605)

The specific profile No. 3 can only be configured by the PC software **GridVis** but not directly at UMG96S. For this profile, a connection between UMG96S and PC via serial interface (RS232 or RS485) is mandatory.

Format

Format of the rotation profile:

STRING

Byte 1 = row 1,

Bit1 = 1. measured value table,

Bit2 = 2. measured value table,

...

Bit8 = 8. measured value table.

Byte 2 = row 2,

Bit1 = 1. measured value table,

Bit2 = 2. measured value table,

...

Bit8 = 8. measured value table

....

Byte 32 = row 32,

Bit1 = 1.measured value table,

Bit2 = 2. measured value table,

....

Bit8 = 8. measured value table.

Measured value indications

After net return, the UMG96S always shows the first measured value table of the actual measured value profile. To keep a better overview over the selection of the measured values, only a part of the available measured values is programmed for calling up in the measured value indications, when the device is delivered. If other measured values are required in the display of the UMG96S, another indication profile can be selected.

In the overview of the measured value indication, "A01" corresponds to the values of voltage L-N.

Indication profile No.0 (See page 86 to 89)

	A	B	C	D	E	F	G	H
01	x		x	x				
02	x		x	x				
03	x	x	x	x				
04	x	x	x	x				
05	x	x	x					
06	x	x	x	x				
07	x	x	x					
08	x	x	x					
09	x	x	x					
10	x	x	x					
11	x	x	x					
12	x	x	x					
13	x	x	x					
14	x	x	x					
15	x							
16	x	x						
17	x							
18	x	x	x	x				
19	x	x	x					
20	x	x	x	x	x	x	x	x
21	x	x	x	x	x	x	x	x
22	x	x	x	x	x	x	x	x
23	x	x	x	x	x	x	x	x
24	x	x	x	x	x	x	x	x
25	x	x	x	x	x	x	x	x
26	x	x	x	x	x	x	x	x
27	x	x	x	x	x	x	x	x
28	x	x	x	x	x	x	x	x
29	x	x	x	x	x	x	x	x
30	x	x	x	x	x	x	x	x
31	x	x	x	x	x	x	x	x
32	x	x	x	x	x	x	x	x

Indication profile (Addr. 060)

Setting range: 0 .. 3

0 - Indication profile 0, fix.

1 - Indication profile 1, fix.

2 - Indication profile 2, fix.

3 - Indication profile 3, specifically.

The UMG96S is delivered with an indication profile 1. The specific profile No. 3 can only be programmed by PC software **GridVis**.

Indication profile No.1 (See page 86 to 89)

	A	B	C	D	E	F	G	H
01	x		x	x				
02	x		x	x				
03	x	x	x	x				
04	x	x	x	x				
05	x	x	x					
06	x	x	x	x				
07	x	x	x					
08	x	x	x					
09	x	x	x					
10	x	x	x					
11	x	x	x					
12	x	x	x					
13	x	x	x					
14	x	x	x					
15	x							
16	x	x						
17	x							
18	x	x	x	x				
19	x	x	x					
20	x	x	x	x	x	x	x	x
21	x	x	x	x	x	x	x	x
22	x	x	x	x	x	x	x	x
23	x	x	x	x	x	x	x	x
24	x	x	x	x	x	x	x	x
25	x	x	x	x	x	x	x	x
26	x	x	x	x	x	x	x	x
27	x	x	x	x	x	x	x	x
28	x	x	x	x	x	x	x	x
29	x	x	x	x	x	x	x	x
30	x	x	x	x	x	x	x	x
31	x	x	x	x	x	x	x	x
32	x	x	x	x	x	x	x	x

Indication profile (Addr. 604)

The specific profile No. 3 can be configured by the PC software **GridVis** only, but not directly at UMG96S. For this profile, a connection between UMG96S and PC via serial interface (RS232 or RS485) is mandatory.

Format of the indication profile:

STRING

Byte 1 = row 1,

Bit1 = 1. measured value table,

Bit2 = 2. measured value table,

...

Bit8 = 8. measured value table.

Byte 2 = row 2,

Bit1 = 1. measured value table,

Bit2 = 2. measured value table,

...

Bit8 = 8. measured value table

....

Byte 32 = row 32,

Bit1 = 1.measured value table,

Bit2 = 2. measured value table,

....

Bit8 = 8. measured value table.

Indication profile No.2

(See page 86 to 89)

	A	B	C	D	E	F	G	H
01	x		x	x				
02	x		x	x				
03	x	x	x	x				
04	x	x	x	x				
05	x	x	x					
06	x	x	x	x				
07	x	x	x					
08	x	x	x					
09	x	x	x					
10	x	x	x					
11	x	x	x					
12	x	x	x					
13	x	x	x					
14	x	x	x					
15	x							
16	x	x						
17	x							
18	x	x	x	x				
19	x	x	x					
20	x	x	x	x	x	x	x	x
21	x	x	x	x	x	x	x	x
22	x	x	x	x	x	x	x	x
23	x	x	x	x	x	x	x	x
24	x	x	x	x	x	x	x	x
25	x	x	x	x	x	x	x	x
26	x	x	x	x	x	x	x	x
27	x	x	x	x	x	x	x	x
28	x	x	x	x	x	x	x	x
29	x	x	x	x	x	x	x	x
30	x	x	x	x	x	x	x	x
31	x	x	x	x	x	x	x	x
32	x	x	x	x	x	x	x	x

User password (Addr.011)

To avoid unintentional changing of the programming data, a password can be programmed. After entering the correct user password, a changing into the following programming menu is possible.

When the device is delivered, no password is entered. In this case, the password menu is cancelled, and you reach the current transformer menu at once.

If a user password was programmed, the password menu appears, indicating „000“.

The first number of the password is flashing and can be changed using key 2. Pressing key 1, the next number is selected and flashes.

If the right number combination was entered, you reach the programming menu for the current transformer.

If a changed user password is not known anymore, the device must be sent to the manufacturer.

Delete energy (Addr.009)

The UMG96S contains 4 energy meters, three real energy meters and one reactive energy meter.

Addr.	Description
416	Sum real energy (without reverse running stop)
418	Sum reactive energy (inductive)
422	Sum real energy (consumption or HT)
424	Sum real energy (supply or NT)

The energy meters can only be deleted simultaneously.

To delete the contents of the energy meters, address 009 must be overwritten by „001“.

Field rotation (Addr. 277)

The field rotation and the frequency in phase L1 are indicated in one display.

The field rotation gives an information about the phase sequence within three phase mains. A clockwise rotation is normal.

In UMG96S the phase sequence of the voltage inputs is checked and indicated. Clockwise moving dashes mean a clockwise rotation, a rotation against the clock means an anticlockwise rotation.

The field rotation is only determined, when all measuring and operating voltage has completely been attached. If a phase is missing or two identical phases are connected, the field rotation is not determined, and the dashes stay still within the display.

LCD Contrast (Addr. 012)

The best direction to watch the display is "from below". The LCD contrast of the display can be adapted by the user. The contrast setting is possible in 1-steps in the range of 0 to 7. When the device is delivered, the contrast is set to 3.

0 = Display very dark

7 = Display very light

To have the best result over the full range of temperature, the inner temperature of the instrument is measured and the contrast is amended automatically. This automatic adaption to the temperature is not indicated in contrast setting.

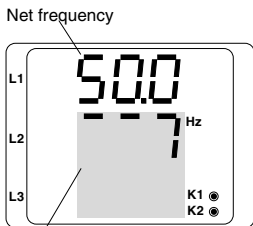

Field rotation

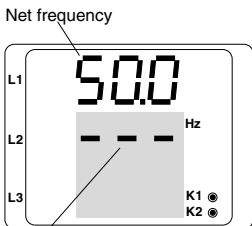

No field rotation determined

Time detection

The UMG96S detects the operating hours of the UMG96S, and the total running time of each comparator. The time is measured with a resolution of 0.1 hours, indicated in hours.

For the call up, the time is marked by the numbers 0 to 6:

- 0 = Operating hours counter (Addr.394)
- 1 = Total run. time, Comparator 1A (Addr.396)
- 2 = Total run. time, Comparator 2A (Addr.398)
- 3 = Total run. time, Comparator 1A (Addr.400)
- 4 = Total run. time, Comparator 2A (Addr.402)
- 5 = Total run. time, Comparator 1A (Addr.404)
- 6 = Total run. time, Comparator 2A (Addr.406)

In the indication, up to 99999.9 h (=11,4 years) can be indicated.

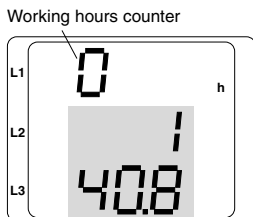

Example:

Indication of operating hours

The UMG96S indicates the operating hours by the number **140,8h**. This corresponds to 140 hours and 60 industrial minutes.

100 industrial minutes correspond to 60 minutes.

In this example, the 80 industrial minutes refer to 48 minutes.

Operating hours counter (Addr. 394)

The operating hours counter measures the time, in which the UMG96S detects and indicates measured data. The operating hours counter cannot be reset.

Total running time comparators

The total running time of a comparator is the sum of all time, in which the comparator result violates its limit. The total running time of each comparator can be reset individually.

Serial number (Addr. 911)

The serial number, which is indicated by the UMG96S, is a 6 digit part of the serial number on type plate.

The serial number cannot be changed.

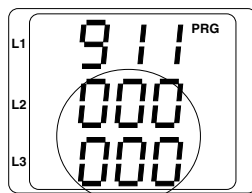

Indicated serial number

XX00-0000

Serial number on type plate

Software Release (Addr. 913)

The internal software of the UMG96S is improved and expanded continuously. The software release of the device is given by a 3 digit number. The software release cannot be changed by the user.

Hardware expansion (Addr. 914)

The available options of the UMG96S can be called up under the address 914. For each available option, a Bit is set. The result is a binary value, that is indicated in decimal form by the UMG96S.

Option		Description
Hex	Binary	
0x01	0000 0001	Memory (EEPROM)
0x02	0000 0010	Clock
0x04	0000 0100	Analog outputs 1/2
0x08	0000 1000	Digital output or pulse output 1/2
0x10	0001 0000	Digital input 1/2
0x20	0010 0000	Profibus
0x40	0100 0000	RS232
0x80	1000 0000	RS485

Example 1

The UMG96S indicates the decimal value 96 under address 914.

$$96 = 0x60 = 0110\ 0000$$

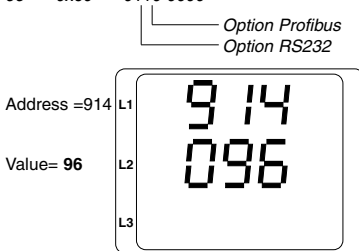

Example 2

The UMG96S displays the decimal value 248 under address 914.

$$248 = 0xf8 = 1111\ 1000$$

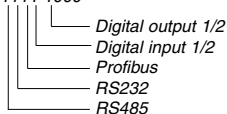

Serial interfaces

The UMG96S can have up to three serial interfaces, depending on the different available version.

Profibus DP
RS232
RS485

These serial interfaces are not separated galvanically. The RS232 and RS485 interface cannot be used at the same time.

The Profibus interface can be operated at the same time with RS232 or RS485 interface.

Automatic recognition of the interface

If both interfaces are connected, the UMG96S recognizes by the signals, if a device is connected at RS232. The data transmission is carried out via RS232.

If no device is recognized at RS232, the data transmission is carried out via RS485 interface.

Interface selection (Addr. 062)

The selection of the RS232 and RS485 interface is carried out on address 062:

0 = Automatic recognition
1 = RS232
2 = RS485

Modem operation (Addr. 070)

Via RS232 or RS485 interface, the UMG96S can be connected to an analogue modem. To enable the UMG96S to transmit data via an analogue modem, address 070 must be overwritten with the value 1.

Address 070 = 0 => Modem operation = No

Address 070 = 1 => Modem operation = Yes

The connection between RS232 interface and analogue modem is done by a modem cable (option). The modem cable, part no. 08.01.503, does not belong to the contents of delivery of the RS232 interface.

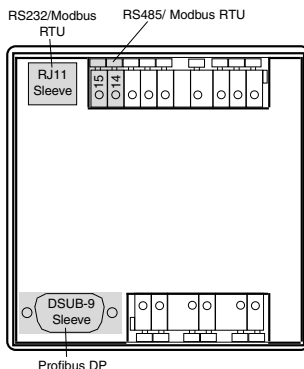

Diagr. Back side of UMG96S.

Device address (Addr. 000)

If several devices are connected via RS485 or Profibus interface, the master (PC or PLC) can tell those devices by their device address only. Within a network, each device UMG96S must have its own device address.

Up to 255 device addresses can be entered.

Baud rate (Addr. 001)

For RS232 and RS485 interface, the following common baud rate can be set.

Baud rate	: 0 - 9.6kBit/s
	1 - 19.2kBit/s
	2 - 38.4kBit/s

Fest eingestellt:

Data bits	: 8
Parity	: none
Stop bits (UMG96S)	: 2
Stop bits (external)	: 1 or 2

MODBUS RTU

Via MODBUS RTU Protocol you have access to the data of parameter list and measured value list.

Transmission parameters

RTU- Mode with CRC-Check.

Realized functions

Read Holding Register, Function 03

Preset Multiple Registers, Function 16

The sequence of the bytes is high before low byte.

Example: Reading of voltage L1-N

The voltage L1-N is deposited under the address 200. Voltage L1-N is available in INT format.

The device address here is supposed with address = 01.

The "Query Message" looks as follows:

<u>Description</u>	<u>Hex</u>	<u>Comment</u>
Device address	01	UMG96S, Address = 1
Function	03	"Read Holding Reg."
Start addr. Hi	00	0200dez = 00C8hex
Start addr. Lo	C8	
Ind. values Hi	00	2dez = 0002hex
Ind. values Lo	02	
Error Check	-	

The "Response" of the UMG96S might look as follows:

<u>Description</u>	<u>Hex</u>	<u>Comment</u>
Device address	01	UMG96S, Address = 1
Function	03	
Byte counter	06	
Data	00	00hex = 00dez
Data	E6	E6hex = 230dez
Error Check (CRC)	-	

The retrieved voltage L1-N of address 0200 is 230V.



Attention!

Maximum 120 Byte can be read in one lot/block.

RS232 interface

The possible distance between two RS232 devices depends on the used cable and baud rate. As an estimation, for a baud rate of 9600 Baud, a distance of 15m should not be exceeded (maximum 30m).

The allowed ohmic load must be higher than 3kOhm and the capacitive load effected by the cable must be smaller than 2500pF.

With the PC cable for the RS232 interface (2m) (optionally available) the maximum baud rate is 38,4kBit/s.

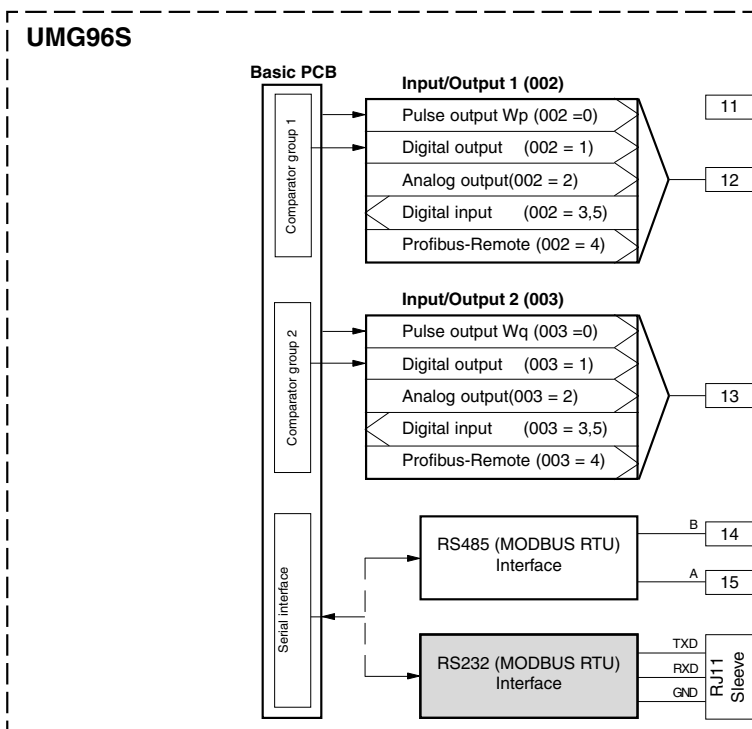

Connection example

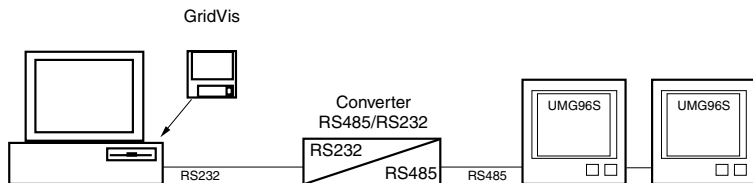

Diagr. Connect UMG96S via an interface converter to a PC.

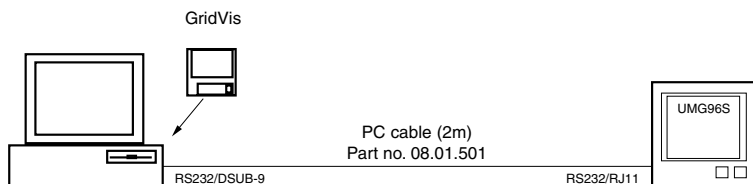

Diagr. Connect the UMG96S to a PC via PC cable.

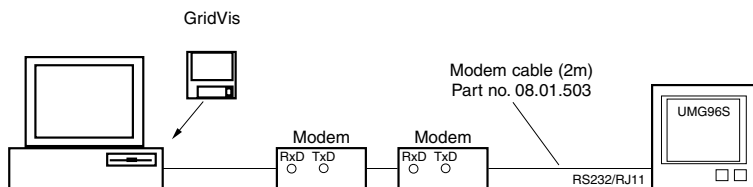

Diagr. Connect the UMG96S to PC via modem.

PC cable

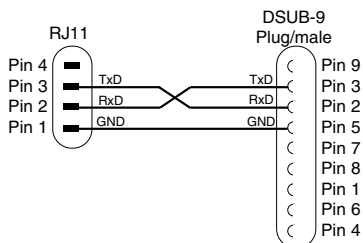

Diagr. PC cable, part no. 08.01.501 (2m)

Modem cable

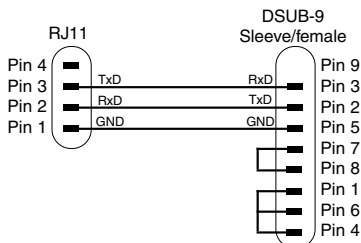

Diagr. Modem cable, part no. 08.01.503 (2m)

Fieldbus (RS485)

Termination resistors

All units shall be connected in a single line bus structure. Up to 32 units can be located within one segment. Use termination resistors at both ends of each segment.

Repeaters must be used to connect the segments if more than 32 units or longer lines are needed.

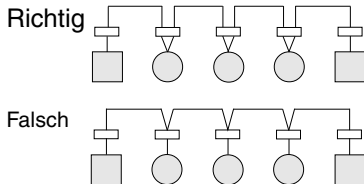

□ Terminal block within cabinet

○ Device with RS485 interface (without terminal resistor)

■ Device with RS485 interface (with terminal resistor included)

UMG96S

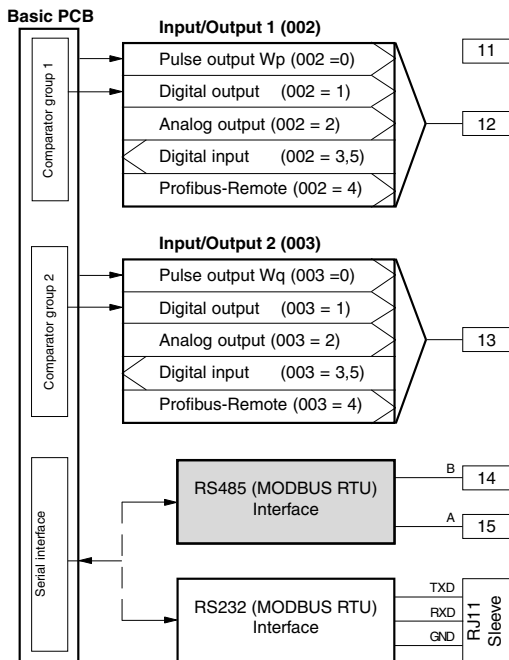

Shielding

Use shielded twisted pair cable for the RS485 bus. To ensure sufficient shielding the cable shield connection must be short and plane-style. Do not use pigtail shield connection.

Kabeltyp

Unitronic Li2YCY(TP)2x2x0,22 (Lapp Kabel)

Unitronic BUS L2/FIP 1x2x0,64 (Lapp Kabel)

Cable length

1200m at 38400 baud.

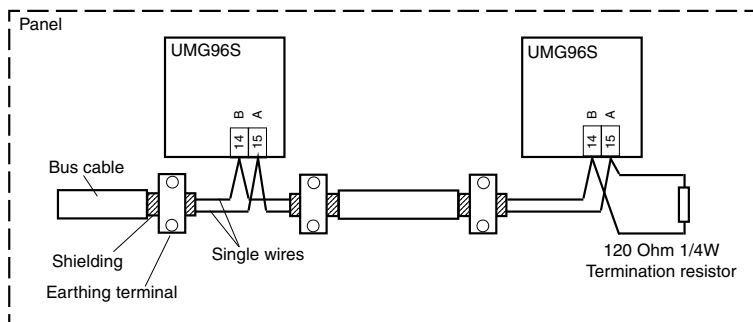

For the wiring of the Modbus connection, CAT cables are not suitable. Please use the recommended cables.

Profibus DP

The UMG96S has a 9-pole SubD sleeve on the back side. On this sleeve, a RS485 interface is wired, which is operated by Profibus DP protocol. Via this RS485 interface, up to 32 participants can be connected. If more participants must be connected, a repeater must be interconnected.



Attention!

The RS232/RS485 interface and the Profibus interface are not separated galvanically from each other.

GSD file

The main data of the UMG96S has got the file name „U96S0781.GSD“.

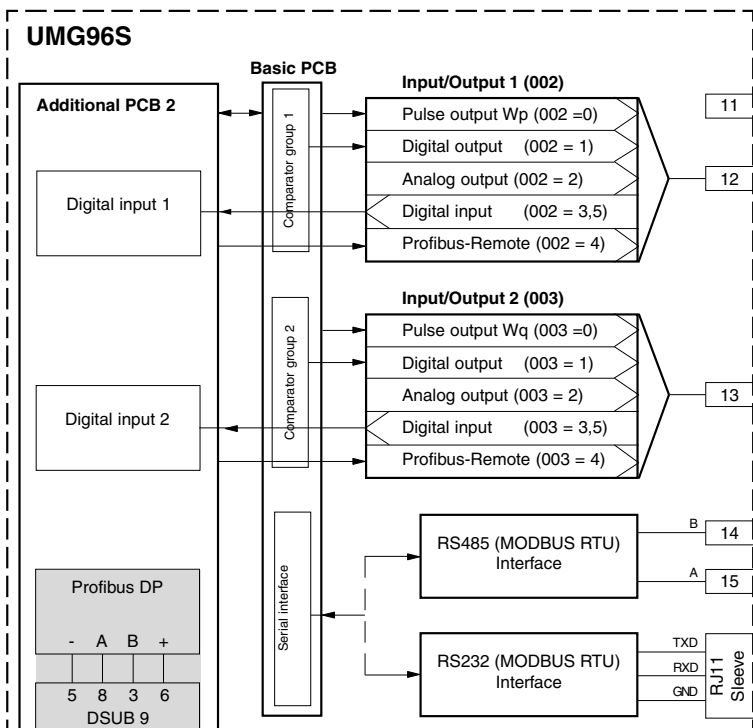

Cable length

The allowed cable length depends on the used cable and the baud rate. The length of the cable is determined by the distance between the bus driver of the first instrument and the bus driver of the last instrument.

We can only recommend shielded cables, which correspond to the standard EN50170-2 wire type A. This cable type can be provided by all leading cable manufacturers.

The allowed cable length, using cable type A is:

Baud rate [kBit/s]	9,6	19,2	45,45	93,75	187,5	500	1500
Cable length [m]	1200	1200	1200	1200	1000	400	200

Termination resistors

Each bus segment must be terminated by a termination resistor. The termination resistors may be contained in the plugs of some manufacturers, and can be switched on optionally.

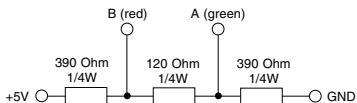

Attention!

If the feeding voltage for the resistors is taken from the UMG96S, the Profibus can be short-circuited in case the UMG96S does not get a sufficient operating voltage. The communication on Profibus might break down.

In order to avoid this effect, the +5V and GND for the termination resistors must be feeded independently.

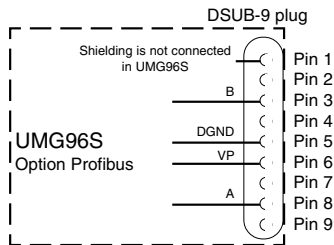

Diagr. Bus connection for Profibus DP

Profibus profiles

There are many measured values available for transmission. To keep the data to be transmitted via Profibus small in number, only a selection of the possible measured data will be transmitted by UMG96S. The selected measured values are combined in 16 different profiles. The programming of specific data is not possible. *The profiles have the description of profile number 1 to 16.*

If a certain profile is required by the Profibus master, please write the desired profile number into the first Byte of the output range of the PLC.

The UMG96S supplies the input range of the PLC with the first 2 Bytes of the actual profile number and the condition of the three comparators.

If not all values of the selected profile are needed, you can pick the first measured values from a profile only.

Via the 2nd Byte of the output range of the PLC, the two outputs of the UMG96S can be activated. The relation is:

Output 1 = Input/Output 1 = Terminal 12

Output 2 = Input/Output 2 = Terminal 13

Profile formats

The measured values can be retrieved in 14 profiles in integer and floating point format. Additionally, the formats "high before low byte" or "low before high byte" can be provided. Measured values in integer format do not contain current and voltage transformer ratios.

Profibus profile No.	Format
1..14 1..14 + 31	Integer format Float formats (4Byte)

Table: Measured values "low before high byte"

Profibus profile No.	Format
1..14 + 128 1..14 + 31 + 128	Integer format Float formats (4Byte)

Table: Measured values "high before low byte"

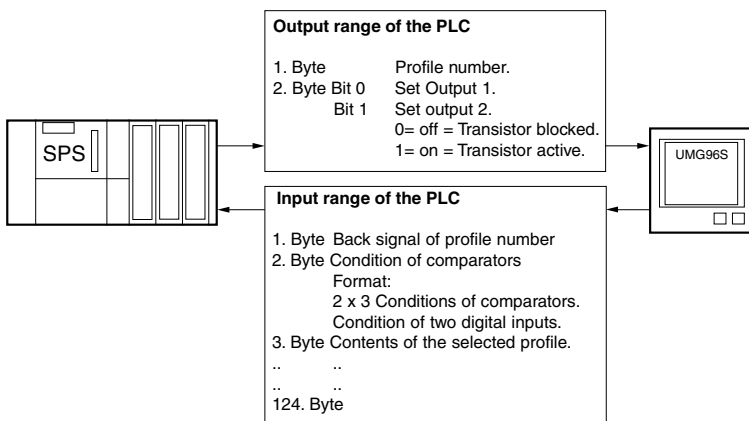

Diagr. Data transmission PLC - UMG96S.

Lists "Profibus profiles", integer size

Profibus profile No.1

Value	Bytes
Q1	2
Q2	2
Q3	2
S1	2
S2	2
S3	2
Frequency	2
Uln L1	2
Uln L2	2
Uln L3	2
UL1-L2	2
UL2-L3	2
UL1-L3	2
IL1	2
IL2	2
IL3	2
P1	2
P2	2
P3	2
Cos-phi L1	2
Cos-phi L2	2
Cos-phi L3	2
Frequency	2
P_sum	2
Q_sum	2
S_sum	2
Cos_phi_sum	2
I_sum in N	2
Real ener. (Adr.416)	4
Reactive energy	4
thd_u_L1	2
thd_u_L2	2
thd_u_L3	2
tdh_i_L1	2
tdh_i_L2	2
tdh_i_L3	2
Sum	56Bytes

Profibus profile No.2

Value	Bytes
Uln L1	2
Uln L2	2
Uln L3	2
UL1-L2	2
UL2-L3	2
UL1-L3	2
IL1	2
IL2	2
IL3	2
P1	2
P2	2
P3	2
Cos-phi L1	2
Cos-phi L2	2
Cos-phi L3	2
Frequency	2
P_sum	2
Q_sum	2
S_sum	2
Cos_phi_sum	2
I_sum in N	2
Real ener. (Adr.416)	4
Reactive energy	4
thd_u_L1	2
thd_u_L2	2
thd_u_L3	2
tdh_i_L1	2
tdh_i_L2	2
tdh_i_L3	2
Sum	62Bytes

Profibus profile No.3

Value	Bytes
eeprom_timer	4
Comp_timer_1	4
Comp_timer_2	4
Comp_timer_3	4
Comp_timer_4	4
Comp_timer_5	4
Comp_timer_6	4
Sum	28Bytes

Profibus profile No.5

Values	Bytes
P_sum	2
Q_sum	2
S_sum	2
Cos_phi_sum	2
I_sum in N	2
Real ener. (Adr.422)	4
Real ener. (Adr.424)	4
React.enrg.(Adr.418)	4
Real enr. ²⁾ (Adr.416)	4
Scheinarbeit ¹⁾	4
Sum	30 Bytes

Profibus profile No.7

Values	Bytes
Real ener. (Adr.422)	4
Real ener. (Adr.424)	4
React.enrg.(Adr.418)	4
eeprom_timer	4
Real enr. ²⁾ (Adr.416)	4
Scheinarbeit ¹⁾	4
Sum	24Bytes

Profibus profile No.4

Value	Bytes
I_mean_L1	2
I_mean_L2	2
I_mean_L3	2
P_mean_L1	2
P_mean_L2	2
P_mean_L3	2
Q_mean_L1	2
Q_mean_L2	2
Q_mean_L3	2
S_mean_L1	2
S_mean_L2	2
S_mean_L3	2
P_sum_mean	2
Q_sum_mean	2
I_sum_mean	2
S_sum_mean	2
phi_sum_mean	2
Sum	34Bytes

Profibus profile No.6

Value	Bytes
ct_prim	2
ct_sec	2
vt_prim	2
vt_sec	2
Field rotation	2
eeprom_timer	4
Comp_timer_1	4
Comp_timer_2	4
Comp_timer_3	4
Comp_timer_4	4
Comp_timer_5	4
Comp_timer_6	4
Sum	38Bytes

Messwert	Format					
	Integer			Float		
	resolution	unit		resolution	unit	
Current	1	1	mA	0,01	0,01	A
Voltage	0,1		V	0,1		V
Real power	0,1	1	W	0,1	1(x10)	W
Apperent power	0,1	1	VA	0,1	1(x10)	VA
Reactive power	0,1	1	var	0,1	1(x10)	var
Energie		1	Wh/varh		0,01(x10)	kWh/kvarh
CosPhi	0,01	0,01	-kap/+ind	0,01	0,01	-kap/+ind
THD I	0,1	0,1	%	0,1	0,1	%
THD U	0,1	0,1	%	0,1	0,1	%
Frequency	0,01	0,01	Hz	0,1	0,1	Hz



Measured values in integer format do not respect the transformer ratio. Measured values in floating point format contain the transformer ratio. (value in the UMG 96S display = transformer ratio PLC x solution)

In the Profibus profiles no. 33, 35, 36, 38, 43 and 47, the measured values real energy, reactive energy, Psum, Qsum and Ssum are given reduced by a factor 10. No specific profiles can be assembled.

1) Ab Firmware Rel.1.09

2) Wirksamkeit ohne Rücklaufsperr.

Profibus profile 8

Values	Bytes
thd_i_L1	2
thd_i_L2	2
thd_i_L3	2
dft_i_1_L1	2
dft_i_1_L2	2
dft_i_1_L3	2
dft_i_3_L1	2
dft_i_3_L2	2
dft_i_3_L3	2
dft_i_5_L1	2
dft_i_5_L2	2
dft_i_5_L3	2
dft_i_7_L1	2
dft_i_7_L2	2
dft_i_7_L3	2
dft_i_9_L1	2
dft_i_9_L2	2
dft_i_9_L3	2
dft_i_11_L1	2
dft_i_11_L2	2
dft_i_11_L3	2
dft_i_13_L1	2
dft_i_13_L2	2
dft_i_13_L3	2
dft_i_15_L1	2
dft_i_15_L2	2
dft_i_15_L3	2
Sum 54Bytes	

Profibus profile 9

Values	Bytes
thd_u_L1	2
thd_u_L2	2
thd_u_L3	2
dft_u_1_L1	2
dft_u_1_L2	2
dft_u_1_L3	2
dft_u_3_L1	2
dft_u_3_L2	2
dft_u_3_L3	2
dft_u_5_L1	2
dft_u_5_L2	2
dft_u_5_L3	2
dft_u_7_L1	2
dft_u_7_L2	2
dft_u_7_L3	2
dft_u_9_L1	2
dft_u_9_L2	2
dft_u_9_L3	2
dft_u_11_L1	2
dft_u_11_L2	2
dft_u_11_L3	2
dft_u_13_L1	2
dft_u_13_L2	2
dft_u_13_L3	2
dft_u_15_L1	2
dft_u_15_L2	2
dft_u_15_L3	2
Sum 54Bytes	

Profibus profile 10

Values	Bytes
tdh_i_L1	2
thd_i_L2	2
thd_i_L3	2
thd_u_L1	2
thd_u_L2	2
thd_u_L3	2
dft_i_3_L1	2
dft_i_3_L2	2
dft_i_3_L3	2
dft_u_3_L1	2
dft_u_3_L2	2
dft_u_3_L3	2
dft_i_5_L1	2
dft_i_5_L2	2
dft_i_5_L3	2
dft_u_5_L1	2
dft_u_5_L2	2
dft_u_5_L3	2
dft_i_7_L1	2
dft_i_7_L2	2
dft_i_7_L3	2
dft_u_7_L1	2
dft_u_7_L2	2
dft_u_7_L3	2
Sum 48Bytes	

Profibus profile 11

Values	Bytes
dft_i_9_L1	2
dft_i_9_L2	2
dft_i_9_L3	2
dft_u_9_L1	2
dft_u_9_L2	2
dft_u_9_L3	2
dft_i_11_L1	2
dft_i_11_L2	2
dft_i_11_L3	2
dft_u_11_L1	2
dft_u_11_L2	2
dft_u_11_L3	2
dft_i_13_L1	2
dft_i_13_L2	2
dft_i_13_L3	2
dft_u_13_L1	2
dft_u_13_L2	2
dft_u_13_L3	2
dft_i_15_L1	2
dft_i_15_L2	2
dft_i_15_L3	2
dft_u_15_L1	2
dft_u_15_L2	2
dft_u_15_L3	2
Sum 48Bytes	

Profibus profile 12

Values	Bytes
P_sum_max	2
P_sum_max_mean	2
I_sum_max	2
I_sum_max_mean	2
phi_sum_max	2
S_sum_max	2
Q_sum_max	2
Uln L1_max	2
Uln L2_max	2
Uln L3_max	2
Uln L1_min	2
Uln L2_min	2
Uln L3_min	2
UL1-L2_max	2
UL2-L3_max	2
UL1-L3_max	2
UL1-L2_min	2
UL2-L3_min	2
UL1-L3_min	2
IL1_max	2
IL2_max	2
IL3_max	2
P1_max	2
P2_max	2
P3_max	2
Q1_max	2
Q2_max	2
Q3_max	2
S1_max	2
S2_max	2
S3_max	2

Sum **62Bytes****Profibus profile 13**

Values	Bytes
thd_i_L1_max	2
thd_i_L2_max	2
thd_i_L3_max	2
dft_i_1_L1_max	2
dft_i_1_L2_max	2
dft_i_1_L3_max	2
dft_i_3_L1_ma	2
dft_i_3_L2_ma	2
dft_i_3_L3_ma	2
dft_i_5_L1_ma	2
dft_i_5_L2_ma	2
dft_i_5_L3_ma	2
dft_i_7_L1_ma	2
dft_i_7_L2_ma	2
dft_i_7_L3_ma	2
dft_i_9_L1_max	2
dft_i_9_L2_max	2
dft_i_9_L3_max	2
dft_i_11_L1_max	2
dft_i_11_L2_max	2
dft_i_11_L3_max	2
dft_i_13_L1_max	2
dft_i_13_L2_max	2
dft_i_13_L3_max	2
dft_i_15_L1_max	2
dft_i_15_L2_max	2
dft_i_15_L3_max	2

Sum **54Bytes****Profibus profile 14**

Values	Bytes
thd_u_L1_max	2
thd_u_L2_max	2
thd_u_L3_max	2
dft_u_1_L1_max	2
dft_u_1_L2_max	2
dft_u_1_L3_max	2
dft_u_3_L1_max	2
dft_u_3_L2_max	2
dft_u_3_L3_max	2
dft_u_5_L1_max	2
dft_u_5_L2_max	2
dft_u_5_L3_max	2
dft_u_7_L1_max	2
dft_u_7_L2_max	2
dft_u_7_L3_max	2
dft_u_9_L1_max	2
dft_u_9_L2_max	2
dft_u_9_L3_max	2
dft_u_11_L1_max	2
dft_u_11_L2_max	2
dft_u_11_L3_max	2
dft_u_13_L1_max	2
dft_u_13_L2_max	2
dft_u_13_L3_max	2
dft_u_15_L1_max	2
dft_u_15_L2_max	2
dft_u_15_L3_max	2

Sum **54Bytes****Profibus profile 15**

Values	Bytes
IL1 meas. value	2
IL1 mean value	2
Psum meas. value	2
CosPhisum meas.	2
IN meas. value	2
IL2 meas. value	2
IL3 meas. value	2
UL1-L2 meas. val.	2

Sum**16Bytes****Profibus profile 16**

Values	Bytes
UL1-N mean value	2
UL2-N mean value	2
UL3-N mean value	2
UL1-L2 mean value	2
UL2-L3 mean value	2
UL3-L1 mean value	2
PL1 mean value	2
PL2 mean value	2
PL3 mean value	2
IL1 mean value	2
IL2 mean value	2
IL3 mean value	2
QL1 mean value	2
QL2 mean value	2
QL3 mean value	2
SL1 mean value	2
SL2 mean value	2
SL3 mean value	2
Psum mean value	2
Qsum mean value	2
IN mean value	2
Ssum mean value	2
Phisum mean val.	2

Sum **46Bytes**

Inputs and outputs

The terminals 12 and 13 at UMG96S can be assigned to the following functions:

- 0 = Pulse output,
- 1 = Digital output,
- 2 = Analog output,
- 3 = Digital input,
- 4 = Profibus-Remote output (Option),
- 5 = HT/NT changeover via digital input ,
- 6 = Synchronization of storage of profile 1 via digital input.

The desired function (0..6) is written into address 002 related to the terminal 12 or address 003 related to terminal 13.

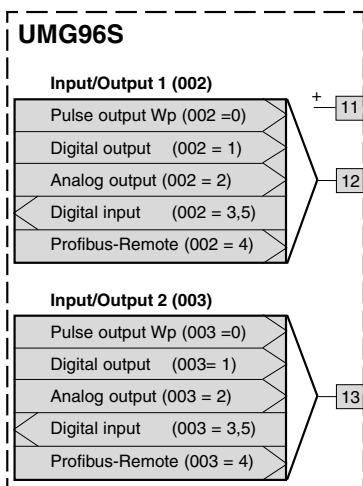
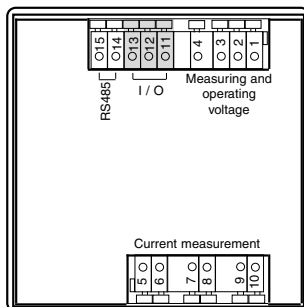

A simultaneous use of the various functions on one terminal is not possible. The simultaneous use of the functions on different terminals is possible. Please note, that the common reference for the terminals 12 and 13 is on terminal 11(+).

combination possibilities of the inputs and outputs:

- a) 2 Digital outputs,
- b) 2 Digital inputs,
- c) 2 Analog outputs,
- d) 1 Digital output and 1 Analog output,
- e) 1 Digital output and 1 Digital input.

Indication of condition

The condition of the switching outputs and inputs is displayed on UMG96S by cycle symbols.

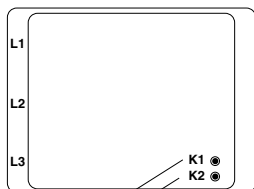

Condition terminal 12

Condition terminal 13

Condition digital inputs:

- There is voltage smaller than 2V.
- There is voltage higher than 20V.

For voltage between 2V and 20V, the condition of the digital input is not defined.

Condition of digital outputs:

- A current smaller than 1mA can flow.
- A current of up to 5mA can flow.

Pulse output

Each **Digit output** can be used as pulse output. Pulse output 1 can transmit **real energy** W_p and pulse output 2 can transmit **reactive energy** W_q .

For both pulse outputs, the **pulse valence** can be set separately via the parameter addresses 004 and 006.

The **Minimum pulse duration** is valid for both pulse outputs, and can be set via parameter address 010.

The collected pulses within a second will be transmitted with the programmed pulse duration and a maximum frequency of 10Hz.

If the measured energy exceeds the set pulse valence, so the maximum frequency for the pulse output would be exceeded, the remaining pulses are stored and given out later. Stored pulses get lost during a net breakdown.

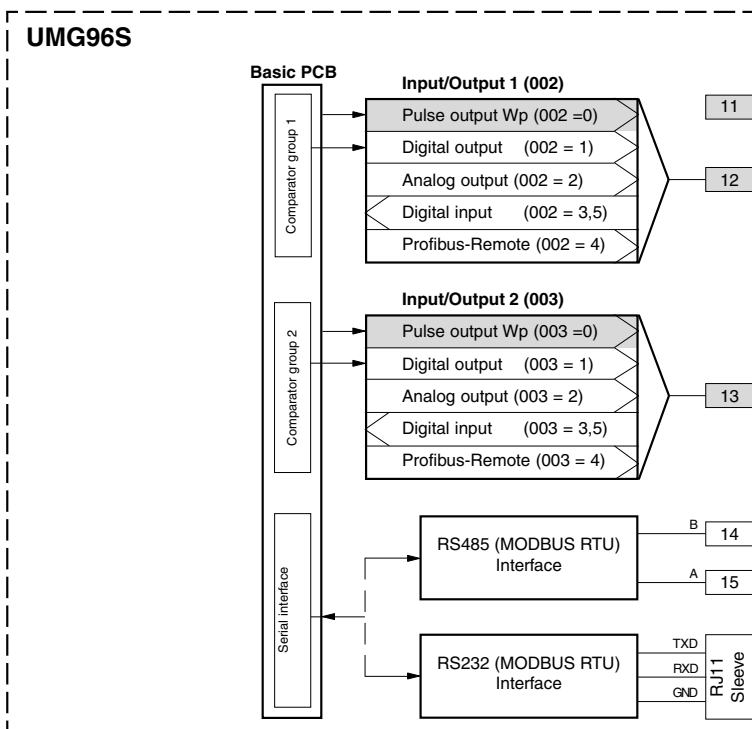

Minimum pulse duration (Addr. 010)

The minimum pulse duration can be programmed on 10 ms steps in a range between 50ms and 1000ms. The shortest pulse pause corresponds to the programmed minimum pulse duration.

At a minimum pulse duration of 50ms the maximum pulse frequency is 10Hz. If less pulses must be transmitted, the pulse pause becomes longer. The programmed minimum pulse duration of 50ms remains constantly.

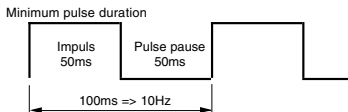

Diagr. Maximum pulse frequency at minimum pulse duration of 50ms.

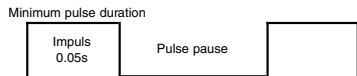

Diagr. Pulse frequency <10Hz at minimum pulse duration of 50ms.

Pulse valence

The pulse valence tells you, how much energy is related to one pulse (Wh or kvarh).

$$\text{Pulse valence} = \frac{\text{energy}}{\text{max. pulse frequency} * 3600\text{s}}$$

Pulse frequency in Wh/pulse

Energy at Wh

Max. puls frequency at Hz

The pulse valence may not be confused with the meter constant. The meter constant is given in

Meter constant = rotations per kWh

The correspondance between pulse valence and meter constant can be seen in the following relations:

Meter constant = 1 / pulse valence

Pulse valence = 1 / meter constant



Attention!

The apparent energy cannot be transmitted via puls output.



Attention!

The pulse pause is not proportional to power.



Attention!

When the real energy meter with **reverse running stop** works, pulses are only given out while consumption of energy. As the reactive energy meter works with **reverse running stop**, pulses are only transmitted at inductive load.

Example: Program pulse output

The UMG96S shall measure real energy in a distribution, and transmit it via pulse output to a data collecting device. The distribution provides a real power of 400kW. The data collecting device can retrieve pulse frequencies up to 50Hz.

At UMG96S, the **pulse output**, the **minimum pulse duration** and the **pulse valence** must be programmed.

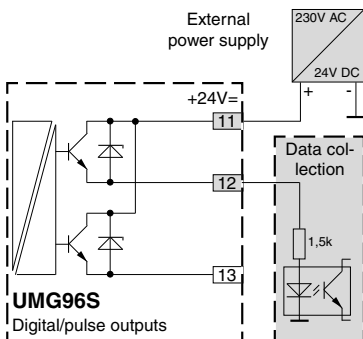

Diagr: Connection example for the connection of the terminals 11 and 13 as pulse output.

1.) Select pulse output

Assign terminal 12 to the function pulse output.
Input/Output 1 Addr.002=0

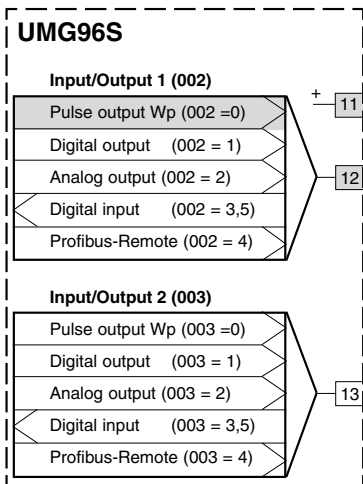

2.) Determine minimum pulse duration

The UMG96S can transmit pulses with a frequency of up to 10Hz.

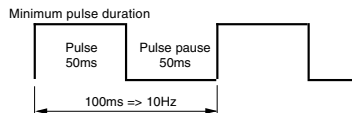

Diagr. Maximum pulse frequency at minimum pulse duration 50ms.

The data collecting device can retrieve pulses with a frequency of 50Hz in this example. The minimum pulse duration at UMG96S can be set to 50ms.

Minimum pulse duration Addr.010 = 005

3.) Determination of pulse valence

The energy, which is consumed within 1 hour can be calculated as:

$$\text{Energy} = \text{Real power} * \text{time}$$

$$\text{Energy} = 400kW * 1h$$

$$\text{Energy} = 400kWh$$

If a pulse valence of 400kWh per pulse is set, the UMG96S transmits one pulse per hour at full load, which corresponds to a pulse frequency of

$$= 1 \text{ pulse/h}$$

$$= 1 \text{ pulse}/3600\text{Sec.}$$

$$= 1/3600 \text{ Hz}$$

$$= 0,00028 \text{ Hz}$$

With this pulse valence, very few pulses are transmitted. Supervision of energy in the range of minutes is not possible.

But UMG96S can provide up to 10 pulses per second (10Hz), and the data collecting device can detect 50 pulses per second (50Hz). A possible solution is to programm the UMG96S to send a frequency of 10Hz at 400kW (or for safety reasons 500kW).

$$= 500kWh \quad \text{Energy per hour}$$

$$= 500kWh / 3600$$

$$= 0,14kWh$$

$$= 140Wh \quad \text{Energy per second}$$

$$= 140Wh / 10$$

$$= 14Wh \quad \text{Energy in 1/10 sec.}$$

This means, if 10 pulses are sent per second with a valence of 14Wh, this corresponds to the power of 500kW for one hour.

$$\text{Pulse valence} = \frac{\text{energy}}{\text{max. pulse frequency} * 3600s}$$

Pulse frequency in Wh/pulse

Energy at Wh

Max. puls frequency at Hz

$$\text{Pulse valency} = \frac{500000Wh}{10Hz * 3600s}$$

$$\text{Pulse valency} = 14Wh/Pulse$$

$$\text{Pulse valence Addr. 004} = 14$$

Digital output

Two digital outputs can be assigned to the terminals 12 and 13 of UMG96S. For digital output 1 a 001 must be written to parameter address 002 and for digital output 2, a 001 must be written to parameter address 003 eine 001.

The result of a limit supervision (388,392) will be given out by the corresponding digital output.

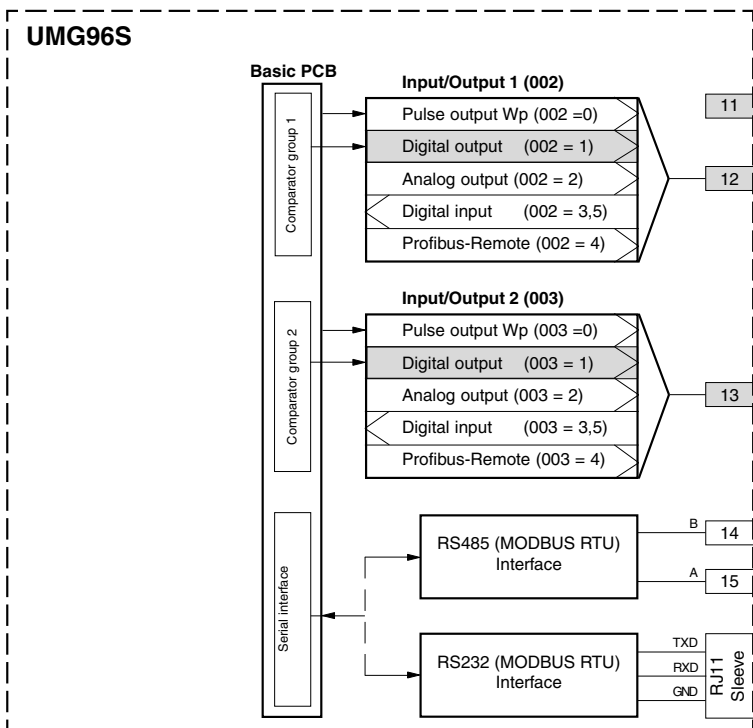

Example: Current supervision in N

If the current in N is higher than 100A for 60 seconds, digital output 1 shall be active for at least 2 minutes.

The following programmings must be carried out:

1. Comparator

We select comparator group 1 for the limit, as this is the only group to influence digital output 1. As only one limit is supervised, we select comparator A and program as follows:

Program the address of the measured value to be supervised of comparator A.

Addr. 015 = 278 (Current in N)

The measured values for comparator B and C are set to 0.

Addr. 020 = 0 (comparator is inactive)

Addr. 025 = 0 (comparator is inactive)

The limit is set to.

Addr. 013 = 100 (100A)

For the minimum time of 2 minutes, the digital output 1 must be switched on while exceeding the limit.

Addr. 016 = 120 seconds

For a run up time of 60 seconds, the limit must be exceeded.

Addr. 064 = 60 seconds

The **Operator** for comparison between measured value and limit.

Addr. 017 = 0 (corresponds to >=)

2. Inputs and outputs

Terminal 12 gets the function **Digital output 1**.

Addr. 002 = 1 (Digital output)

Result

If the current in neutral exceeds 100A for more than 60 seconds, digital output 1 is active for at least 2 minutes. Relay K1 attracts.

If memory profile 4 is selected for storage in data memory (Option), the results of the comparators will be stored with date and time under address 500.

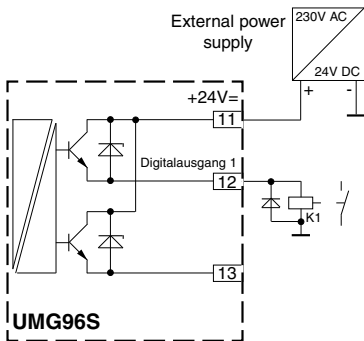

Diagr.: Connection example for digital output 1.

Limit supervision

For limit supervision, two comparator groups with 3 comparators each are available. The results of the comparators A, B and C can be combined with AND or OR and the result can be inverted optionally. The total combination result of comparator group 1 can be assigned to digital output 1 and the combination result of comparator 2 can be assigned to digital output 2.



Attention!

At UMG96S only the first three digits of a parameter can be set.

With GridVis, all digits of a parameter can be set.

Because of the measuring accuracy of the UMG96S, only the first three digits of a parameter are relevant.

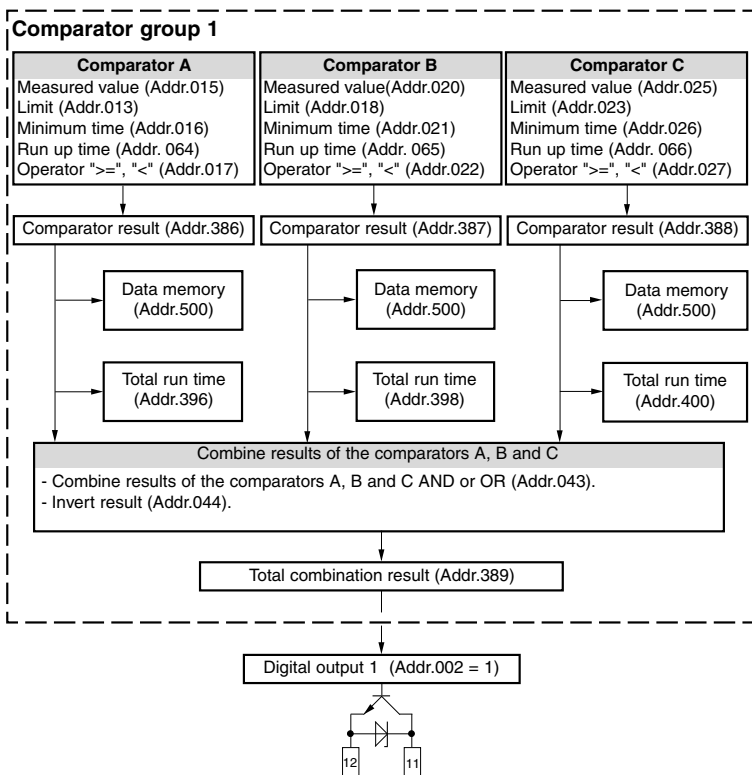

Diagr. Limit supervision with digital output 1.

Measured value (Addr. 015)

The measured value indicates the address of the supervised measured value. The following values can be assigned:

000 = Comparator inactive.

001 = the comparator result can be written externally (Modbus RTU).

200 .. 400 = Measured values of measured value list.

Limit (Addr. 018)

The limit serves a constant of the type LONG. The limit is compared to the corresponding measured value.

Minimum time (Addr. 016)

For the duration of the minimum time, the comparator result remains active (Addr.389). The minimum time can be programmed in the range of 1...900 seconds.

Run up time (Addr. 064)

At least for the duration of the run up time, a violation of the limit must be active to change the comparator result.

The run up time can be programmed in the range of 1...900 seconds.

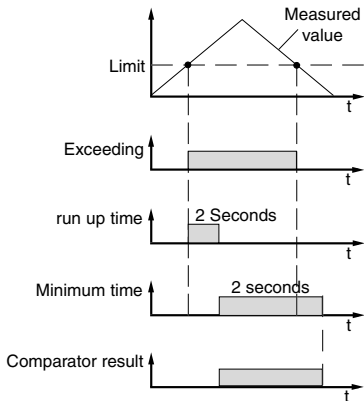

Diagr. Example, Limit violation.

Operator (Addr. 017)

There are two operators available for the comparison of measured value and limit.

Operator = 0 means **higher than (\geq)**

Operator = 1 means **smaller than ($<$)**

Comparator result (Addr.386)

The result of the comparison of measured value and limit is the comparator result.

The correspondence is:

0 = No limit violation.

1 = Limit violation.

Data memory (Addr. 500)

Changes of the comparator results can be stored in the memory (option), as long as profile 4 for the memory (addr. 056) was activated.

Total running time (Addr. 396)

This is the sum of all times, for which the limit was violated.

Combination (Addr. 043)

Combines the results of the comparators A, B and C **AND** or **OR**.

Invert result (Addr. 044)

The result of the combination (Addr. 043) can be inverted or not.

Total combination result (Addr. 389)

The combined comparator results of the comparators A, B and C are in the total combination result.

Analog output

The UMG96S with the additional PCB 1 contains 2 analogue outputs. Each analogue output can provide a current of 4-20mA. For the operation, an external power supply 24VDC is mandatory.

Four parameters must be programmed for one analogue output.

Input/Output (Addr. 002,003)

Switches the analogue output to the terminals of the UMG96S.

Measured value (Addr. 047, 052)

Indicates the measured value, which shall be transmitted by the analogue output.

Scale starting value (Addr. 050, 054)

The scale starting value corresponds to the measured value, for which the minimum current of 4mA should flow.

Scale end value (Addr. 048, 053)

The scale end value corresponds to the measured value, for which the maximum current of 20 mA should flow.

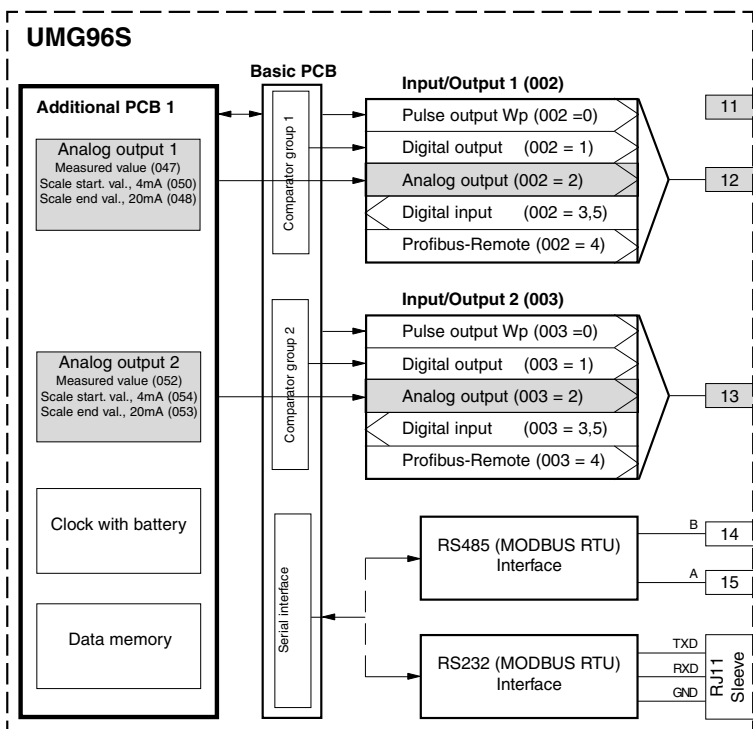

Programming example, Cosphi

There is a difference in the scaling of the Cosphi on the UMG and in the GridVis.

UMG96S		GridVis
Display	Programming	
1,00	100	1,00
0,01	1	0,01
0,00	0	0,00

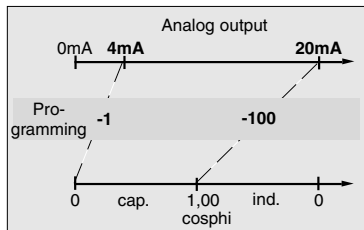

Diagr.: Programming example 1; Analog output Cosphi = capacitive.

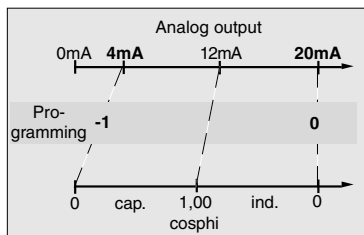

Diagr.: Programming example 2; Analog output Cosphi = capacitive and inductive.

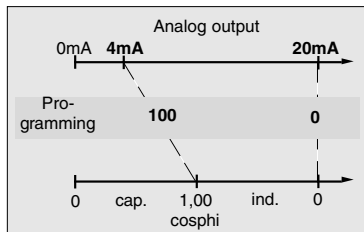

Diagr.: Programming example 3, Analog output Cosphi = inductive.

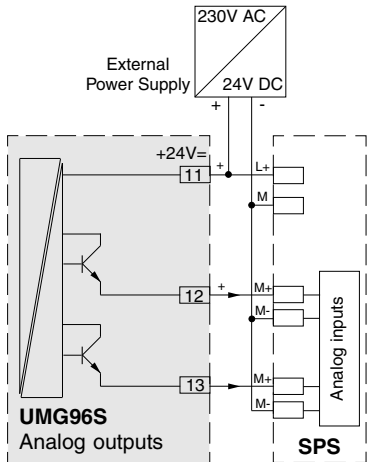

Diagr. Connection of the analog outputs to a PLC.

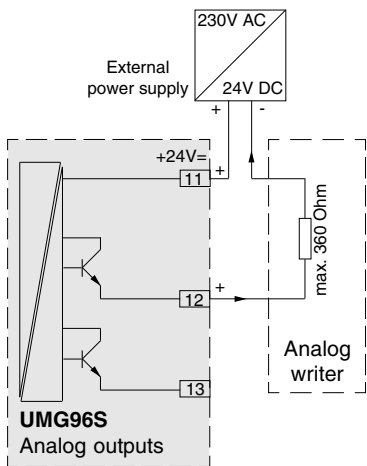

Diagr. Connection of an analog output to an analog writer.

Digital input

The UMG96S with additional PCB 2 has 2 digital inputs. For the operation of the digital inputs, an external power supply of 24VDC is mandatory.

A digital input (Addr. 002, Addr. 003) can have 2 functions:

3 = Supervision of the condition of the digital input.

5 = HT/NT changeover.

Condition of the digital inputs

If a digital input is assigned to the function "3", the condition of the digital inputs can be called up via the addresses 420 and 421.

If a voltage is attached to a digital input, a 1 is written into address (420/421). if no voltage is attached, a 0 is written.

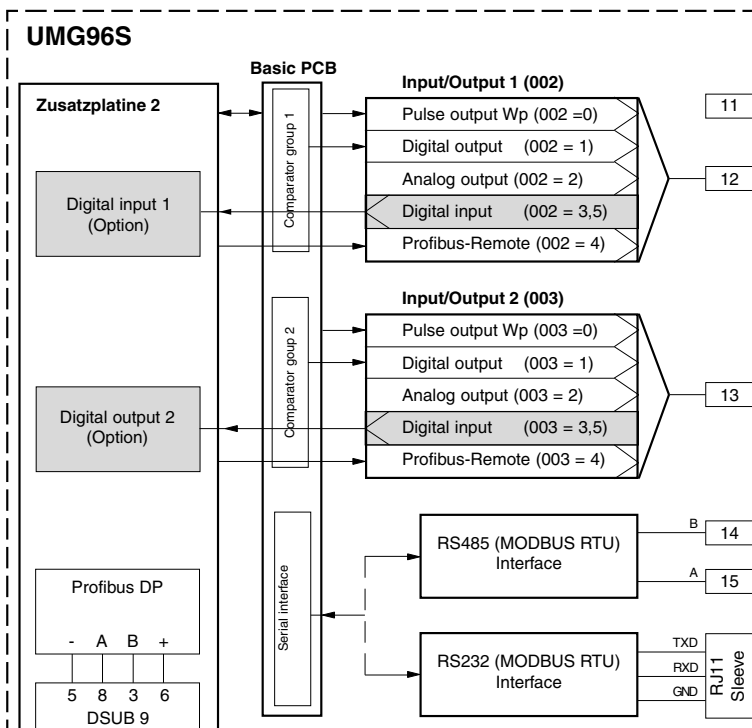

HT/NT tariff changeover

If the **digital input 1** assigned to function "5" one can change between low and high tariff using the input. If there is no voltage at the input, a 0 is written to address 071. If there is voltage at the input, a 1 is written to address 071.

If the **digital input 2** assigned to function "5" one can change between low and high tariff using the input. If there is no voltage at the input, a 0 is written to address 072. If there is voltage at the input, a 1 is written to address 072.

Adr.071=0; real energy counter low tariff active.

Adr.071=1; real energy counter high tariff active.

Adr.072=0; reactive energy counter high tariff active.

Adr.072=1; reactive energy counter high tariff active.

Adr.002=5; Digital input 1 is used for high/low tariff changeover for real energy.

Adr.002=6; Digital input 1 is used for high/low tariff changeover for real and reactive energy.

Adr.003=5; Digital input 2 is used for high/low tariff changeover for reactive energy.

Adr.003=6; Digital input 2 is used for high/low tariff changeover for real and reactive energy.

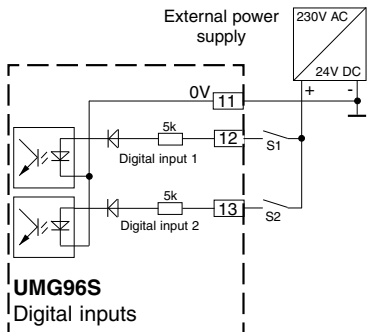

Diagr.: Connection example for the digital inputs.

Only the inductive reactive energy is used for the counters high and low tariff. If no changeover is programmed, the inductive energy is saved on address 426 and the capacitive energy on address 428.

Only the consumed real power is used for the counters high and low tariff. If no changeover is programmed, the consumed real energy is saved on address 422, and the supplied real energy on address 424.

Changeover is not possible via Profibus.

Memory

In UMG96S is always an EEPROM memory included to store the configuration data and minimum and maximum values. Optionally, a data memory (FLASH memory) is available for storage of measured values and events. Both memories do not need a battery for storage.

Data memory (Option)

Measured values and events can be stored with date and time within the memory. If the memory is full, the most obsolete data are overwritten. The memory starts with address 500. Up to 32768 data blocks with 18 byte can be stored. After net breakdown (L1, L2 and L3 fail simultaneously) the last 45 seconds can get lost.

Data block

1 Block consists of:

2 Byte Data number

4 Byte time stamp

10 Byte Data string

1 Byte Profile number

1 Byte Error information

Time stamp

In the time stamp, the number of seconds since 1.1.1970 up to the time of storage are counted.

Data string

In the data string, the data of one of the 4 possible profiles are deposited. A data string may contain several measured values. In the stored measured values, the set current and voltage transformer ratio is not respected.

Profile number

In the profile number is the memory profile, which is stored in the data string.

Error information

If the storage of data was interrupted by a net breakdown (L1, L2 and L3 fail simultaneously), it will be mentioned within the error information.
Byte = 0 The data are o.k.

Byte <> 0 The stored data are wrong.

Data memory (056)

Measured values and events are available in 4 defined profiles for storage. Each of the 4 memory profiles can be selected individually or together with other profiles.

Contents of Addr. 056	Profile Number					
	1	2	3	4	5	6
0						
1	x					
2		x				
3	x	x				
4			x			
5	x		x			
6		x	x			
7	x	x	x			
8				x		
9	x			x		
10		x		x		
11	x	x		x		
.						
.						
.						
63	x	x	x	x	x	x

After the net return and after the set averaging time, the selected profiles will be stored in the memory.

The time of storage for memory profile 1 can be synchronized by a digital input (Option) additionally. Changing the input signal from 0 to 1, the memory profile will be stored. The time of the next storage is determined by the averaging time P.

Memory profile 1

In memory profile 1, the power mean values are combined:

- Mean value P in L1
- Mean value P in L2
- Mean value P in L3
- Mean value Q Sum
- Mean value S Sum

The data of profile 1 are always stored after the averaging time P.

Memory profile 2

In memory profile 2, the current mean values are combined:

- Mean value I in L1
- Mean value I in L2
- Mean value I in L3
- Mean value I in N
- Mean value CosPhi Sum

The data in memory profile 2 are always stored after the averaging time I.

Memory profile 3

In memory profile 3, the energy meters are combined:

- real energy (consumption)
- Reactive energy (inductive)

The contents of the energy meters are stored once per hour.

Memory profile 4

In memory profile 4, all comparator results are combined:

- Comparator 1 (Bit 1)
- Comparator 2 (Bit 2)
- Comparator 3 (Bit 3)
- Comparator 4 (Bit 4)
- Comparator 5 (Bit 5)
- Comparator 6 (Bit 6)

Each changing of the 6 comparator outputs will be stored in the corresponding Bit 1-6 of a Byte. The time stamp is valid for the first Byte. Each further Byte describes the condition of the comparator one second later. In Byte 10, the conditions of the comparator outputs are deposited at the time: time stamp plus 10 seconds.

Memory profile 5

In memory profile 5, the voltage mean values are combined:

- Mean value U_{L1-N}
- Mean value U_{L2-N}
- Mean value U_{L3-N}
- Mean value P_{Summe}
- Mean value Q_{Summe}

The data of profile 5 are always stored after the averaging time U.

Memory profile 6

In memory profile 6, the voltage mean values are combined:

- Mean value U_{L1-L2}
- Mean value U_{L2-L3}
- Mean value U_{L3-L1}
- Mean value P_{Summe}
- Mean value Q_{Summe}

The data of profile 6 are always stored after the averaging time U.

Tables

Parameter list

In the parameter list all necessary settings for correct operation of the UMG96S, such as CT data or device address, are mentioned. The values in the parameter list can be written and read. Date and time in address 700 are an exception and can be written only. On address 410 of the measured value list, date and time can be read in seconds since 1.1.1970.

Measured value list

The measured value list contains the measured and calculated measured values, condition data of the inputs and outputs as well as the protocolled values for reading out.

Formats

CHAR	= 1 Byte
INT	= 2 Byte; (high before low Byte)
LONG	= 4 Byte; (high before low Byte)
STRING1	= 32 Byte; Byte 1 = row 1, Bit1=1.meas. value table, Bit2=2.meas. value table ... Byte 2 =row 2, Bit1=1. meas. value table, Bit2=2.meas.value table ...
STRING2	= 6 Byte; Hour, minute, second, day, month, year
FDATA	= 2 Byte; Data set number 4 Byte; Time since 1.1.1970 10 Byte; Data string 1 Byte; Profile number 1 Byte; Error information

Representation of CosPhi within UMG96S

	← capacitive	1,00	inductive →	
Measured value indication	0,00cap	1,00	1,00	0,00ind
measured value list and data memory	-100	0	0	+100
Analog outputs and switching outputs	-1	-100	+100	+0



Attention!

Only the PC software GridVis can use the maximum setting range of some parameters. At UMG96S, values can be entered up to 999999.



Attention!

For some parameters, only software GridVis can use the full setting range. At UMG96S, only values up to 999999 can be set.



The measured values (current, voltage, power etc.) in the measured value lists do not contain transformer ratios.

Parameter list

Addr.	Description	Setting range	Type	Unit	Presetting
000	UMG96S Device address	1 .. 255	CHAR	-	1
001	Baud rate (RS232 and RS485)	0 .. 2	CHAR ¹⁾	kbps	0
002	Input/Output 1, Type	0 .. 6	CHAR ^{2a)}	-	0
003	Input/Output 2, Type	0 .. 6	CHAR ^{2b)}	-	0
004	Pulse valence, Digital output 1	0 .. 100000	PULS	Wh	1,00 ⁵⁾
006	Pulse valence, Digital output 2	0 .. 100000	PULS	varh	1,00 ⁵⁾
008	Delete min. and max. values	0 .. 1	CHAR	-	0
009	Delete energy	0 .. 1	CHAR	-	0
010	Min. pulse duration, Digital output 1/2	5 .. 99	CHAR ³⁾	ms	5=50ms
011	User password	0 .. 999	INT	-	000
012	LCD contrast	0 .. 7	CHAR	-	3
013	Comparator 1A, limit	-999999999 .. 999999999	LONG		0
015	Comparator 1A, measured value	0 .. 999	INT ⁶⁾		000
016	Comparator 1A, Min. on time	1 .. 899	INT	Sec.	1
017	Comparator 1A, Operator	0, 1	CHAR ⁴⁾		0
018	Comparator 1B, limit	-999999999 .. 999999999	LONG		
020	Comparator 1B, measured value	0 .. 999	INT ⁶⁾		
021	Comparator 1B, min. on time	1 .. 899	INT	Sec.	1
022	Comparator 1B, Operator	0, 1	CHAR ⁴⁾		0
023	Comparator 1C, limit	-999999999 .. 999999999	LONG		
025	Comparator 1C, measured value	0 .. 999	INT ⁶⁾		
026	Comparator 1C, min. on time	1 .. 899	INT	Sec.	1
027	Comparator 1C, Operator	0, 1	CHAR ⁴⁾		0
028	Comparator 2A, limit	-999999999 .. 999999999	LONG		
030	Comparator 2A, measured value	0 .. 999	INT ⁶⁾		
031	Comparator 2A, min. on time	1 .. 899	INT	Sec.	1
032	Comparator 2A, Operator	0, 1	CHAR ⁴⁾		0
033	Comparator 2B, limit	-999999999 .. 999999999	LONG		
035	Comparator 2B, measured value	0 .. 999	INT ⁶⁾		
036	Comparator 2B, min. on time	1 .. 899	INT	Sec.	1
037	Comparator 2B, not/inverted	0, 1	CHAR ⁴⁾		0
038	Comparator 2C, limit	-999999999 .. 999999999	LONG		

¹⁾ 0 = 9,6kBit/s; 1 = 19,2kBit/s; 2 = 38,4kBit/s

^{2a)} 0 = Pulse output, 1 = digital output, 2 = analog output, 3 = digital input, 4 = Profibus-Remote output, 5 = HT/NT changeover, real energie, 6 = HT/NT changeover, real energie and reactive energie.

^{2b)} 0 = Pulse output, 1 = digital output, 2 = analog output, 3 = digital input, 4 = Profibus-Remote output, 5 = HT/NT changeover, reactive energie, 6 = HT/NT changeover, real energie and reactive energie.

³⁾ Min. pulse duration = setting range * 10 [ms]

⁴⁾ 0 = higher than, 1 = smaller than

⁵⁾ Reading/writing 100=1,00

⁶⁾ 0 = Comparator not used, 1 = remote, 200-424 = measured values

Parameter list Part 2

Addr.	Description	Setting range	Type	Unit	Presetti.
040	Comparator 2C, measured value	0 .. 999	INT ⁶⁾		
041	Comparator 2C, min. on time	1 .. 899	INT	Sec.	1
042	Comparator 2C, Operator	0, 1	CHAR ⁴⁾		0
043	Combine result of comparators. (0,1,2)	0, 1	CHAR ¹⁾	-	0
044	Invert result (0,1,2) .	0, 1	CHAR ²⁾	-	0
045	Combine result of comparators (3,4,5)	0, 1	CHAR ¹⁾	-	0
046	Invert result (3,4,5).	0, 1	CHAR ²⁾	-	0
047	Measured value analogue output 1	0 .. 999	INT		0
048	Analog output 1, 20mA	-999999999 .. 999999999	LONG		0
050	Analog output 1, 4mA	-999999999 .. 999999999	LONG		0
052	Measured value for analogue output 2	0 .. 999	INT		0
053	Analog output 2, 20mA	-999999999 .. 999999999	LONG		0
055	Analog output 2, 4mA	-999999999 .. 999999999	LONG		0
056	Data memory	0 .. 15	CHAR	-	0
057	Averaging time, for I	0 .. 6	CHAR ³⁾	-	6
058	Averaging time, for P	0 .. 6	CHAR ³⁾	-	6
059	Rotation time	0 .. 60	CHAR	Sec.	0
060	Indication profile	0 .. 3	CHAR	-	0
	0 .. 2 = Fix indication profiles				
	3 = Free selectable indication profile				
061	Indication rotation profile	0 .. 3	CHAR	-	0
	0 .. 2 = Fix indication rotation profile				
	3 = Free selectable indication rot. profile				
062	Selection of interface	0, 1, 2	CHAR	-	0
	0 = Autom. recognition				
	1 = RS232				
	2 = RS485				
063	Net frequency	0, 1, 2	CHAR	-	0
	0 = Net frequency of Phase L1				
	1 = 50Hz				
	2 = 60Hz				
064	Comparator 1A, run up time	1 .. 899	INT	Sec.	0
065	Comparator 1B, run up time	1 .. 899	INT	Sec.	0
066	Comparator 1C, run up time	1 .. 899	INT	Sec.	0
067	Comparator 2A, run up time	1 .. 899	INT	Sec.	0
068	Comparator 2B, run up time	1 .. 899	INT	Sec.	0
069	Comparator 2C, run up time	1 .. 899	INT	Sec.	0
070	Modem operation (0 = no, 1 = yes)	0, 1	CHAR	-	0
071	Real energy, changeover (0=HT, 1=NT)	0, 1	CHAR	-	0
072	Reac. ener., changeover (0=HT, 1=NT)	0, 1	CHAR	-	0
073	Averaging time, for U	0 .. 6	CHAR ³⁾	-	6

Parameter list Part 3

Addr.	Description	Setting range	Type	Unit	Presettin.
600	Current transformer, primary ⁶⁾	1 .. 10000	INT	A	5
601	Current transformer, secondary ⁶⁾	1 .. 5	INT	A	5
602	Voltage transformer, primary ⁶⁾	100 .. 60000	INT	V	400 ⁴⁾
603	Voltage transformer, secondary ⁶⁾	100 .. 400	INT	V	400 ⁴⁾
604	Indication profile, actual	5)	STRING1	-	-
605	Indication rotation profile, actual	5)	STRING1	-	-
700	Date and time	5)	STRING2	-	-
701	Option clock, yes=1, no= 0	read only	CHAR	-	-
702	Ring buffer, Data set number, address	read only	INT	-	-
703	Option Ringpuffer, ja=1, nein= 0	read only	CHAR	-	-
800	Write in EEPROM	0 .. 4	CHAR	-	0
	Bit 1 = 1, Write calibration data.				
	Bit 2 = 1, Write programming data.				
	Bit 4 = 1, Write counter.				
	Bit 8 = 1, Write min./max. values.				
911	Serial number	read only	LONG	-	#####
913	Software Release	read only	INT	-	###
914	Hardware Expansion	read only	INT	-	###



Attention!

For some parameters, only software GridVis can use the full setting range. At UMG96S, only values up to 999999 can be set.

¹⁾ 0 = OR, 1 = AND

²⁾ 0 = not inverted, 1 = inverted

³⁾ 0 = 5Sec., 1 = 10Sec., 2 = 30Sec., 3 = 60Sec., 4 = 300Sec., 5 = 480Sec., 6 = 900Sec.

⁴⁾ In 300V standard version: 400V; In 150V special version: 100V.

⁵⁾ These values can only be read and written with GridVis.

⁶⁾ The parameters for current and voltage transformer ratios can be read at UMG96S only.

Measured value list

Addr.	Description	Type	Unit	Solution
200	Voltage L1-N	INT	V	0,1
201	Voltage L2-N	INT	V	0,1
202	Voltage L3-N	INT	V	0,1
203	Voltage L1-L2	INT	V	0,1
204	Voltage L2-L3	INT	V	0,1
205	Voltage L3-L1	INT	V	0,1
206	Current in L1	INT	mA	1
207	Current in L2	INT	mA	1
208	Current in L3	INT	mA	1
209	Real power L1	INT	W	0,1
210	Real power L2	INT	W	0,1
211	Real power L3	INT	W	0,1
212	Reactive power L1	INT	W	0,1
213	Reactive power L2	INT	W	0,1
214	Reactive power L3	INT	W	0,1
215	Apparent power L1	INT	W	0,1
216	Apparent power L2	INT	W	0,1
217	Apparent power L3	INT	W	0,1
218	CosinusPhi in L1	INT	-	0,01
219	CosinusPhi in L2	INT	-	0,01
220	CosinusPhi in L3	INT	-	0,01
221	1. Harmonic U L1-N	INT	V	0,1
222	3. Harmonic U L1-N	INT	V	0,1
223	5. Harmonic U L1-N	INT	V	0,1
224	7. Harmonic U L1-N	INT	V	0,1
225	9. Harmonic U L1-N	INT	V	0,1
226	11. Harmonic U L1-N	INT	V	0,1
227	13. Harmonic U L1-N	INT	V	0,1
228	15. Harmonic U L1-N	INT	V	0,1
229	1. Harmonic U L2-N	INT	V	0,1
230	3. Harmonic U L2-N	INT	V	0,1
231	5. Harmonic U L2-N	INT	V	0,1
232	7. Harmonic U L2-N	INT	V	0,1
233	9. Harmonic U L2-N	INT	V	0,1
234	11. Harmonic U L2-N	INT	V	0,1
235	13. Harmonic U L2-N	INT	V	0,1
236	15. Harmonic U L2-N	INT	V	0,1
237	1. Harmonic U L3-N	INT	V	0,1
238	3. Harmonic U L3-N	INT	V	0,1
239	5. Harmonic U L3-N	INT	V	0,1
240	7. Harmonic U L3-N	INT	V	0,1
241	9. Harmonic U L3-N	INT	V	0,1
242	11. Harmonic U L3-N	INT	V	0,1
243	13. Harmonic U L3-N	INT	V	0,1
244	15. Harmonic U L3-N	INT	V	0,1
245	1. Harmonic I L1	INT	mA	1
246	3. Harmonic I L1	INT	mA	1
247	5. Harmonic I L1	INT	mA	1
248	7. Harmonic I L1	INT	mA	1

Measured value list, part2

Addr.	Description	Type	Unit	Solution
249	9. Harmonic I L1	INT	mA	1
250	11. Harmonic I L1	INT	mA	1
251	13. Harmonic I L1	INT	mA	1
252	15. Harmonic I L1	INT	mA	1
253	1. Harmonic I L2	INT	mA	1
254	3. Harmonic I L2	INT	mA	1
255	5. Harmonic I L2	INT	mA	1
256	7. Harmonic I L2	INT	mA	1
257	9. Harmonic I L2	INT	mA	1
258	11. Harmonic I L2	INT	mA	1
259	13. Harmonic I L2	INT	mA	1
260	15. Harmonic I L2	INT	mA	1
261	1. Harmonic I L3	INT	mA	1
262	3. Harmonic I L3	INT	mA	1
263	5. Harmonic I L3	INT	mA	1
264	7. Harmonic I L3	INT	mA	1
265	9. Harmonic I L3	INT	mA	1
266	11. Harmonic I L3	INT	mA	1
267	13. Harmonic I L3	INT	mA	1
268	15. Harmonic I L3	INT	mA	1
269	THD U L1	INT	%	0,1
270	THD U L2	INT	%	0,1
271	THD U L3	INT	%	0,1
272	THD I L1	INT	%	0,1
273	THD I L2	INT	%	0,1
274	THD I L3	INT	%	0,1
275	Frequency L1	INT	Hz	0,01
276	CosinusPhi, Sum	INT	0,01	-
277	Field rotation	INT ¹⁾	-	-
278	Current in N	INT	mA	1
279	Real power, Sum	INT	W	1
280	Reactive power, Sum	INT	var	1
281	Apparent power, Sum	INT	VA	1
282	Mean value I in L1	INT	mA	1
283	Mean value I in L2	INT	mA	1
284	Mean value I in L3	INT	mA	1
285	Mean value P in L1	INT	W	0,1
286	Mean value P in L2	INT	W	0,1
287	Mean value P in L3	INT	W	0,1
288	Mean value Q in L1	INT	var	0,1
289	Mean value Q in L2	INT	var	0,1
290	Mean value Q in L3	INT	var	0,1
291	Mean value S in L1	INT	VA	0,1
292	Mean value S in L2	INT	VA	0,1
293	Mean value S in L3	INT	VA	0,1
294	Mean value I in N	INT	mA	1
295	Mean value P, Sum	INT	W	1
296	Mean value Q, Sum	INT	var	1

¹⁾ 0 = no field rotation recognized, 1 = clockwise field, -1 = anticlockwise field

Measured value list part 3

Addr.	Description	Type	Unit	Solution
297	Mean value S, Sum	INT	VA	1
298	Max. value I, Sum	INT	mA	1
299	Max. value, P mean value, Sum	INT	W	1
300	Max. value I mean value, Sum	INT	mA	1
301	Max. value, P Sum	INT	W	1
302	Max. value, Q Sum	INT	var	1
303	Max. value, S Sum	INT	VA	1
304	Max. value, CosPhi Sum	INT	-	0,01
305	Min. value, U L1-N	INT	V	0,1
306	Min. value, U L2-N	INT	V	0,1
307	Min. value, U L3-N	INT	V	0,1
308	Max. value, U L1-N	INT	V	0,1
309	Max. value, U L2-N	INT	V	0,1
310	Max. value, U L3-N	INT	-	0,1
311	Min. value, U L1-L2	INT	V	0,1
312	Min. value, U L2-L3	INT	V	0,1
313	Min. value, U L3-L1	INT	V	0,1
314	Max. value, U L1-L2	INT	V	0,1
315	Max. value, U L2-L3	INT	V	0,1
316	Max. value, U L3-L1	INT	V	0,1
317	Max. value, I L1	INT	mA	1
318	Max. value, I L2	INT	mA	1
319	Max. value, I L3	INT	mA	1
320	Max. value, I L1 Mean value	INT	mA	1
321	Max. value, I L2 Mean value	INT	mA	1
322	Max. value, I L3 Mean value	INT	mA	1
323	Max. value, P L1	INT	W	0,1
324	Max. value, P L2	INT	W	0,1
325	Max. value, P L3	INT	W	0,1
326	Max. value, Q L1	INT	var	0,1
327	Max. value, Q L2	INT	var	0,1
328	Max. value, Q L3	INT	var	0,1
329	Max. value, S L1	INT	VA	0,1
330	Max. value, S L2	INT	VA	0,1
331	Max. value, S L3	INT	VA	0,1
332	Max. value, 1. Harmonic U L1-N	INT	V	0,1
333	Max. value, 3. Harmonic U L1-N	INT	V	0,1
334	Max. value, 5. Harmonic U L1-N	INT	V	0,1
335	Max. value, 7. Harmonic U L1-N	INT	V	0,1
336	Max. value, 9. Harmonic U L1-N	INT	V	0,1
337	Max. value, 11. Harmonic U L1-N	INT	V	0,1
338	Max. value, 13. Harmonic U L1-N	INT	V	0,1
339	Max. value, 15. Harmonic U L1-N	INT	V	0,1
340	Max. value, 1. Harmonic U L2-N	INT	V	0,1
341	Max. value, 3. Harmonic U L2-N	INT	V	0,1
342	Max. value, 5. Harmonic U L2-N	INT	V	0,1
343	Max. value, 7. Harmonic U L2-N	INT	V	0,1
344	Max. value, 9. Harmonic U L2-N	INT	V	0,1

Measured value list part 4

Addr.	Description	Type	Unit	Solution
345	Max. value, 11. Harmonic U L2-N	INT	V	0,1
346	Max. value, 13. Harmonic U L2-N	INT	V	0,1
347	Max. value, 15. Harmonic U L2-N	INT	V	0,1
348	Max. value, 1. Harmonic U L3-N	INT	V	0,1
349	Max. value, 3. Harmonic U L3-N	INT	V	0,1
350	Max. value, 5. Harmonic U L3-N	INT	V	0,1
351	Max. value, 7. Harmonic U L3-N	INT	V	0,1
352	Max. value, 9. Harmonic U L3-N	INT	V	0,1
353	Max. value, 11. Harmonic U L3-N	INT	V	0,1
354	Max. value, 13. Harmonic U L3-N	INT	V	0,1
355	Max. value, 15. Harmonic U L3-N	INT	V	0,1
356	Max. value, 1. Harmonic I L1	INT	mA	1
357	Max. value, 3. Harmonic I L1	INT	mA	1
358	Max. value, 5. Harmonic I L1	INT	mA	1
359	Max. value, 7. Harmonic I L1	INT	mA	1
360	Max. value, 9. Harmonic I L1	INT	mA	1
361	Max. value, 11. Harmonic I L1	INT	mA	1
362	Max. value, 13. Harmonic I L1	INT	mA	1
363	Max. value, 15. Harmonic I L1	INT	mA	1
364	Max. value, 1. Harmonic I L2	INT	mA	1
365	Max. value, 3. Harmonic I L2	INT	mA	1
366	Max. value, 5. Harmonic I L2	INT	mA	1
367	Max. value, 7. Harmonic I L2	INT	mA	1
368	Max. value, 9. Harmonic I L2	INT	mA	1
369	Max. value, 11. Harmonic I L2	INT	mA	1
370	Max. value, 13. Harmonic I L2	INT	mA	1
371	Max. value, 15. Harmonic I L2	INT	mA	1
372	Max. value, 1. Harmonic I L3	INT	mA	1
373	Max. value, 3. Harmonic I L3	INT	mA	1
374	Max. value, 5. Harmonic I L3	INT	mA	1
375	Max. value, 7. Harmonic I L3	INT	mA	1
376	Max. value, 9. Harmonic I L3	INT	mA	1
377	Max. value, 11. Harmonic I L3	INT	mA	1
378	Max. value, 13. Harmonic I L3	INT	mA	1
379	Max. value, 15. Harmonic I L3	INT	mA	1
380	Max. value, THD U L1	INT	%	0,1
381	Max. value, THD U L2	INT	%	0,1
382	Max. value, THD U L3	INT	%	0,1
383	Max. value, THD I L1	INT	%	0,1
384	Max. value, THD I L2	INT	%	0,1
385	Max. value, THD I L3	INT	%	0,1



The minimum and maximum values are stored without date and time.

Measured value list part 5

Addr.	Description	Type	Unit	Solution
386	Comparator result 1A	CHAR	-	0/1
387	Comparator result 1B	CHAR	-	0/1
388	Comparator result 1C	CHAR	-	0/1
389	Total result, comparator group 1	CHAR	-	0/1
390	Comparator result 2A	CHAR	-	0/1
391	Comparator result 2B	CHAR	-	0/1
392	Comparator result 2C	CHAR	-	0/1
393	Total result, comparator group 2	CHAR	-	0/1
394	Operation hours meter	LONG	Sec.	0,1h
396	Total running time, comparator 1A	LONG	Sec.	1
398	Total running time, comparator 1B	LONG	Sec.	1
400	Total running time, comparator 1C	LONG	Sec.	1
402	Total running time, comparator 2A	LONG	Sec.	1
404	Total running time, comparator 2B	LONG	Sec.	1
406	Total running time, comparator 2C	LONG	Sec.	1
408	Temperature within device	INT	[°C]	1
409	Internal operation voltage	INT	V	10mV
410	Time since 1.1.1970	LONG	Sec.	1
412	Mean value, CosPhi, Sum	INT	-	0.01
413	Exceeding of measuring range	CHAR	-	
	Bit 1: Exceeding of 6,5Aeff in phase L1			
	Bit 2: Exceeding of 6,5Aeff in phase L2			
	Bit 3: Exceeding of 6,5Aeff in phase L3			
	Bit 4: Free			
	Bit 5: Exceeding of 300Veff in phase L1			
	Bit 6: Exceeding of 300Veff in phase L2			
	Bit 7: Exceeding of 300Veff in phase L3			
	Bit 8: Free			
414	Analog output 0 (4-20mA)	INT	A	10uA
415	Analog output 1 (4-20mA)	INT	A	10uA
416	Sum real energy Wp, without reverse running stop	LONG	Wh	-
418	Sum reactive energy Wq, inductive	LONG	varh	-
420	Condition, Digital input 1	CHAR	-	0/1
421	Condition, Digital input 2	CHAR	-	0/1
422	Sum, real energy Wp, Consumption or HT ¹⁾	LONG	Wh	-
424	Sum, real energy Wp, supply or NT ²⁾	LONG	Wh	-
426	Sum, reactiv energy Wq, kap. or ind/HT ³⁾	LONG	varh	-
428	Sum, reactiv energy Wq, sum or ind/NT ⁴⁾	LONG	varh	-
430	Sum, apparent energy	LONG	VAh	-

1) Consumption, when no tariff changeover is activated.
HT, wenn Adr.2 = 5/6 oder Adr.3 =6.

2) Supply, when no tariff changeover is activated.
NT, wenn Adr.2 = 5/6 oder Adr.3 =6.

3) Capazitiv, when no tariff changeover is activated.
ind/HT, wenn Adr.2 = 6 oder Adr.3 =5/6.

4) Sum, when no tariff changeover is activated.
ind/NT, wenn Adr.2 = 6 oder Adr.3 =5/6.

Measured value list part 6







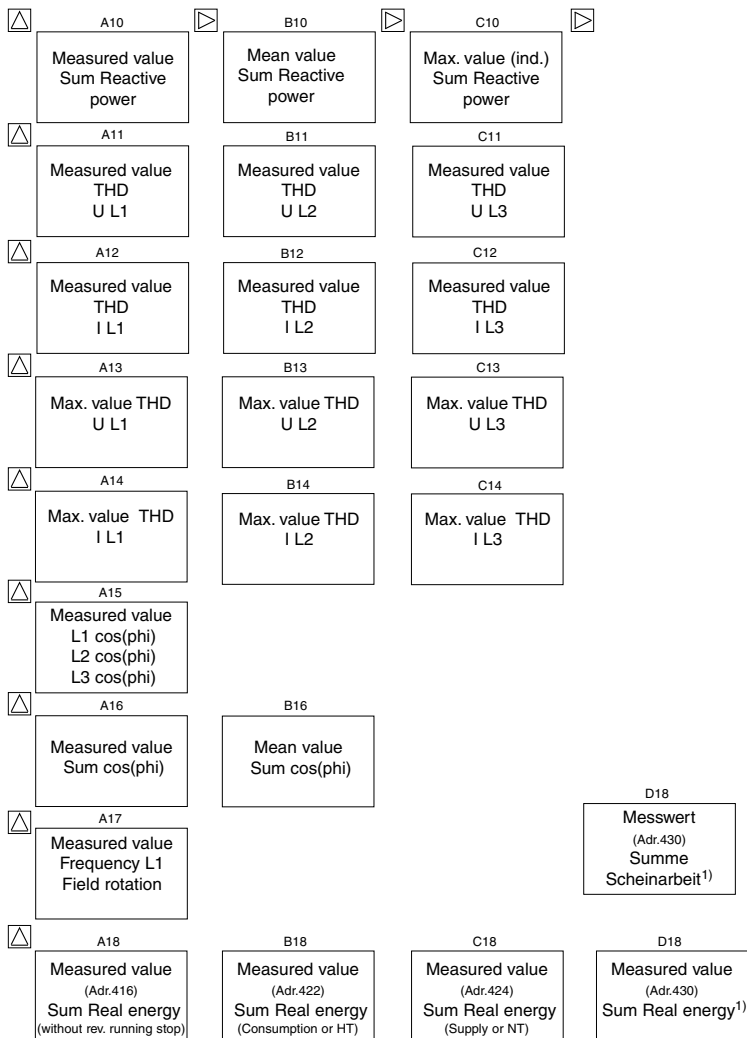



Addr.	Description	Type	Unit	Solution
432	Mean values U_{L1-N}	INT	V	0,1
433	Mean values U_{L2-N}	INT	V	0,1
434	Mean values U_{L3-N}	INT	V	0,1
435	Mean values U_{L1-L2}	INT	V	0,1
436	Mean values U_{L2-L3}	INT	V	0,1
437	Mean values U_{L3-L1}	INT	V	0,1
500	Data memory - data set	FDATA	-	-
501	Data memory - data set	FDATA	-	-
502	Data memory - data set	FDATA	-	-
503	Data memory - data set	FDATA	-	-
504	Data memory - data set	FDATA	-	-
505	Data memory - data set 500-505 decr. data memory pointer 702 while reading	FDATA	-	-
506	Data memory - data set	FDATA	-	-
510	Function 0000h = write act. data memory address into addr. 702 A55Ah = Delete data memory 5AA5h = Set device with presettings.	INT		
520	Measured value indications	STRING		
521	measured value indication, indication rotation	STRING		

Measured value displays, overview

A	B	C	D
<p>A01</p> <p>Measured values L1-N Voltage L2-N Voltage L3-N Voltage</p>	<p>A02</p> <p>Mean values L1-N Voltage L2-N Voltage L3-N Voltage</p>	<p>C01</p> <p>Max. values L1-N Voltage L2-N Voltage L3-N Voltage</p>	<p>D01</p> <p>Min. values L1-N Voltage L2-N Voltage L3-N Voltage</p>
<p>A02</p> <p>Measured values L1-L2 Voltage L2-L3 Voltage L3-L1 Voltage</p>	<p>B02</p> <p>Mean values L1-L2 Voltage L2-L3 Voltage L3-L1 Voltage</p>	<p>C02</p> <p>Max. values L1-L2 Voltage L2-L3 Voltage L3-L1 Voltage</p>	<p>D02</p> <p>Min. values L1-L2 Voltage L2-L3 Voltage L3-L1 Voltage</p>
<p>A03</p> <p>Measured values L1 Current L2 Current L3 Current</p>	<p>B03</p> <p>Mean values L1 Current L2 Current L3 Current</p>	<p>C03</p> <p>Max. values L1 Current L2 Current L3 Current</p>	<p>D03</p> <p>Max. values L1 Current L2 Current L3 Current</p>
<p>A04</p> <p>Measured value Sum Current in N</p>	<p>B04</p> <p>Mean value Sum Current in N</p>	<p>C04</p> <p>Max. value Sum meas. vaues Current in N</p>	<p>D04</p> <p>Max. values Sum mean values Current in N</p>
<p>A05</p> <p>Measured values L1 Real power L2 Real power L3 Real power</p>	<p>B05</p> <p>Mean values L1 Real power L2 Real power L3 Real power</p>	<p>C05</p> <p>Max. values L1 Real power L2 Real power L3 Real power</p>	
<p>A06</p> <p>Measured value Sum Real power</p>	<p>B06</p> <p>Mean value Sum Real power</p>	<p>C06</p> <p>Max. value Sum Real power</p>	<p>D06</p> <p>Max. value Sum Real power, mean</p>
<p>A07</p> <p>Measured values L1 Apparent power L2 Apparent power L3 apparent power</p>	<p>B07</p> <p>Mean values L1 Apparent power L2 Apparent power L3 apparent power</p>	<p>C07</p> <p>Max. values L1 Apparent power L2 Apparent power L3 apparent power</p>	
<p>A08</p> <p>Measured value Sum Apparent power</p>	<p>B08</p> <p>Mean value Sum Apparent power</p>	<p>C08</p> <p>Max. value Sum Apparent power</p>	
<p>A09</p> <p>Measured values L1 Reactive power L2 Reactive power L3 Reactive power</p>	<p>B09</p> <p>Mean values L1 Reactive power L2 Reactive power L3 Reactive power</p>	<p>C09</p> <p>Max. values (ind.) L1 Reactive power L2 Reactive power L3 Reactive power</p>	



¹⁾ Ab Firmware Rel.1.09

 A19 Meas. value (ind) Sum (Adr.418) Reactive energy	 B19 Measured value Sum (Adr.426) Reactive energy kap./HT(ind)	 C19 Measured value Sum (Adr.428) Reactive energy ind./NT(ind)	
 A20 Operating hours counter 1	B20 Comparator 1 Total running time	...	G20 Comparator 6 Total running time
 A21 Measured value 1. Harmonic U L1	B21 Measured value 3. Harmonic U L1	...	H21 Measured value 15. Harmonic U L1
 A22 Measured value 1. Harmonic U L2	B22 Measured value 3. Harmonic U L2	...	H22 Measured value 15. Harmonic U L2
 A23 Measured value 1. Harmonic U L3	B23 Measured value 3. Harmonic U L3	...	H23 Measured value 15. Harmonic U L3
 A24 Measured value 1. Harmonic I L1	B24 Measured value 3. Harmonic I L1	...	H24 Measured value 15. Harmonic I L1
 A25 Measured value 1. Harmonic I L2	B25 Measured value 3. Harmonic I L2	...	H25 Measured value 15. Harmonic I L2
 A26 Measured Value 1. Harmonic I L3	B26 Measured value 3. Harmonic I L3	...	H26 Measured value 15. Harmonic I L3

 Those menus are not displayed with the producer's presetsings.

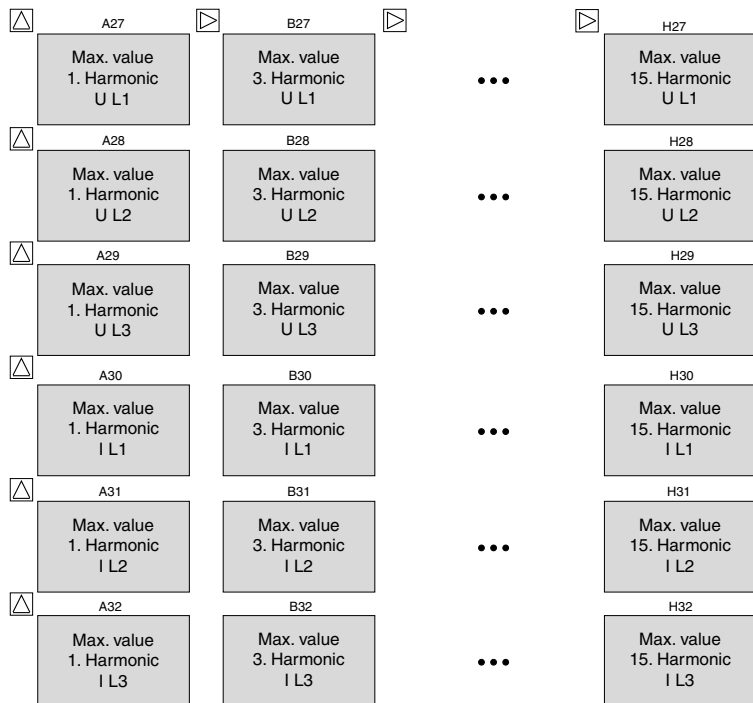

 Those menus are not displayed with the producer's presets.

Indication range and accuracy

Quantity	Indication range	Meas. range ¹⁾	Accuracy ³⁾
Voltage L-N			
300V Standard version	0 .. 34kV	50 .. 300V	+0,5% rng
150V Special version	0 .. 17kV	25 .. 150V	+0,5% rng
Voltage L-L			
300V Standard version	0 .. 60kV	87 .. 520V	+1,0% rng
150V Special version	0 .. 30kV	40 .. 260V	+1,0% rng
Current	0,01 .. 60,0kA	0,01 .. 6A	+0,5% rng
Current in N	0,01 .. 180,0kA	0,01 .. 18A	+1,5% rng
Real power, per phase	0,1W .. 99,9MW	0,1W .. 1,8kW	+1,0% rng
Apparent power, per phase	0,1VA .. 99,9MVA	0,1VA .. 1,8kVA	+1,0% rng
Reactive power, (Q0) per phase	0,1var .. 99,9Mvar	0,1var .. 1,8kvar	+1,0% rng
Real power, Sum	1W .. 99,9MW	1W .. 5,4kW	+1,0% rng
Apparent power, Sum	1VA .. 99,9MVA	1VA .. 5,4kVA	+1,0% rng
Reactive power (Q0), Sum	1var .. 99,9Mvar	1var .. 5,4kvar	+1,0% rng
Harmonics U, 1-15	0 .. 34kV	0,1V .. 300,0V	+2,0% rng
Harmonics I, 1-15	0,01 .. 60,0kA	1mA .. 6000mA	+2,0% rng
THD U, I	0,1% .. 100,0%		+2,0% rng
cos(phi)	0,00i .. 1.00 .. 0,00k	0,00i .. 1.00 .. 0,00k	+ - 1degree
Frequency (of voltage)	45,0 .. 65,0Hz	45,0 .. 65,0Hz	+0,1% rdg
Reactive energy Wq, inductive	0 .. 999.999.999kvarh ⁴⁾		Class 1 ²⁾ (./5A) Class 2 ²⁾ (./1A)
Real energy Wp, supply	0 .. 999.999.999kWh ⁴⁾		Class 1 ²⁾ (./5A) Class 2 ²⁾ (./1A)
Operating hours counter	0 .. 999 999 999h		+2Minutes/day

These specifications presuppose a yearly calibration and a warm up time of 10 minutes.

Used abbreviations:

rng = of measuring range
rdg = of measured value

¹⁾ Measuring range with scale factor = 1, (Current transformer = 5/5A, 1/1A)

²⁾ Accuracy class according to DIN EN62052-11:2003, IEC62052:2003

³⁾ In the range of -10..18°C and 28..55°C an additional error of +0,5%o rng per K must be respected.

⁴⁾ The maximum indication range of real and reactive energy depends on the transformer ratio $v = v_i * v_u$.

v_i = Current transformer ratio.

v_u = Voltage transformer ratio.

Example: 200/5A -> $v_i = 40$

1000/100V -> $v_u = 10$

$v = v_i * v_u$

$v = 40 * 10$

$v = 400$

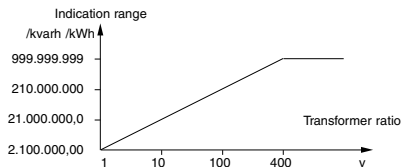

Declaration of conformity

UMG96S fulfills the protection requirements of standard 89/336/EWG in connection to DIN EN 61326 (2002-03) as well as of standard 73/23EWG and 93/68/EWG in connection to EN 61010-1 (2002-08).

Safety regulations

: EN61010-1 08:2002, IEC 61010-1:2001

Requirements of electromagnetical compatibility

: DIN EN61326:2002-03

Noise emission

Basic unit	: DIN EN61326:2002-03, table 4 class B, (residential areas)
Basic unit with option 1	: DIN EN61326:2002-03, table 4 class B, (residential areas)
Basic unit with option 2	: DIN EN61326:2002-03, table 4 class A, (industrial areas)

Noise immunity (industrial areas)

Casing	: Electrostatic discharge immunity test, IEC61000-4-2 (4kV/8kV) : Electromagnetically fields, IEC61000-4-3 (10V/m)
Voltage and supply	: Voltage dips, IEC61000-4-11 (0,5Periode) : Electrical fast transient/burst, IEC61000-4-4 (2kV) : Surge immunity test, IEC61000-4-5 (1kV) : Immunity to conducted disturbances, IEC61000-4-6 (3V)
Input/output, serial interfaces	: Electrical fast transient/burst, IEC61000-4-4 (1kV) : Surge immunity test, IEC61000-4-5 (1kV)

Technical data

Weight	: 250g
Calorific value	: 2,2MJ (610Wh)
Ambient conditions	
Ambient temperature	: -10°C .. +55°C
Storage temperature	: -20°C .. +70°C
Relative humidity	: 15% to 95% without dew
Protection	
Front	: IP40 according to EN60529
Front with seal (Option)	: IP42 according to EN60529
Back side	: IP20 according to EN60529
Mounting position	: optional
Mounting height	: 0 .. 2000m over NN
Pollution degree	: 2
Protection class	: II = without protective wire
Connectable wires	
one wire, more wires, fine wires	: 0,08 - 2,5mm ²
Pin cable socket, conductor sleeves	: 1,5mm ²
	For each terminal, only one wire may be connected!
Inputs and outputs	
Digital outputs	: S0 DIN43864
Type	: NPN-Transistor
Rest current	: < 1mA
Operation current	: max. 50 mA (not short-circuit proof!)
Operation voltage	: 5 .. 24V DC, max. 27V DC
Switching frequency as pulse output	: 10Hz (50ms pulse duration)
Digital inputs (Option)	
Sample frequency	: 1Hz
Current consumption	: max. 5mA
Input signal attached	: >20V DC, max. 27V DC
Input signal not attached	: <2V DC
Analog outputs (Option)	: 4 .. 20mA
Solution	: 8Bit
Accuracy	: +- 1,5% vMb.
Load	: max. 300 Ohm
Reaction time	: 1,5 seconds
Operation voltage, external ripple	: 20V..27VDC : max. 2V, 50Hz

Measurement	
Measuring inputs	
Measuring rate	: 1 measurement/sec.
Rated pulse voltage	: 4kV
Signal frequency	: 45Hz .. 65Hz
Measuring and operating voltage	
Test voltage	: see type plate
	: 2500V AC
	: 300V CATIII
Voltage metering	
Fuse	: 2A .. 10A (medium type)
Frequency of fundamental	: 45Hz .. 65Hz
power consumption (basic instrument)	
Connecting one phase (L-N)	: max. 1,5VA (1,5W)
Connecting all 3 phases (L1/L2/L3-N)	: max. 0,5VA (0,5W) / Phase
Power consumption (basic device with add. PCB 2)	
Connecting one phase (L-N)	: max. 3VA (3W)
Connecting all three phases (L1/L2/L3-N)	: max. 1VA (1W) / Phase
300V Standard version	
Measuring range L-N	: max. 300V AC against ground
Measuring range L-L	: 50 .. 300V AC
Operation voltage L-N	: 87 .. 520V AC
	: 85 (140)* .. 300V AC
150V Special version	
Measuring range L-N	: max. 150V AC against ground
Measuring range L-L	: 25 .. 150V AC
Operation voltage L-L	: 40 .. 260V AC
	: 85 .. 260V AC
Current measurement	
Test voltage	: 150V CATIII, 300V CATII
Power consumption	: 2500V AC
Rated current at ../5A (../1A)	: ca. 0,2 VA
Minimum working current	: 5A (1A)
Limit at ../1A	: 5mA
Limit at ../5A	: 1,2A (sinus shape)
Overload	: 6A (sinus shape)
	: 150A for 2 Sec.
Serial interfaces	
Attention! The serial interfaces are not separated galvanically from each other.	
RS232, RJ11-sleeve (Option)	
Protocol	: MODBUS RTU
Transmission rates	: 9.6, 19.2, 38.4kBit/s
RS485, Spring terminals (Option)	
Protocol	: MODBUS RTU
Transmission rates	: 9.6, 19.2, 38.4kBit/s
RS485, DSUB-9 (Option)	
Protocol	: Profibus DP (V0)
Transmission rates	: 9.6, 19.2, 45.45, 93.75, 187.5, 500, 1500kBit/s
* The smallest operation voltage for devices with option Profibus is 140V AC.	

Dimension sketch

Cut out: $92^{+0,8} \times 92^{+0,8}$ mm

Back side

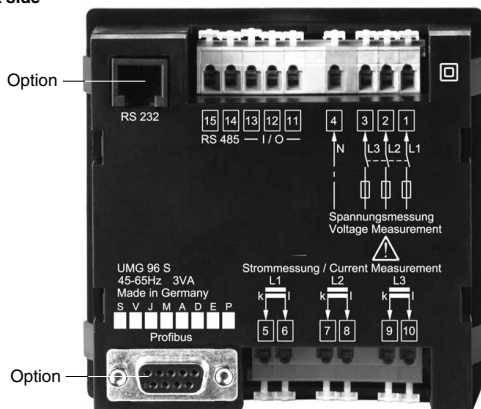

Side view

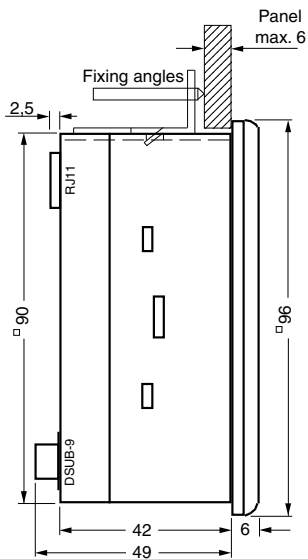

All dimensions in mm

Connection diagrams

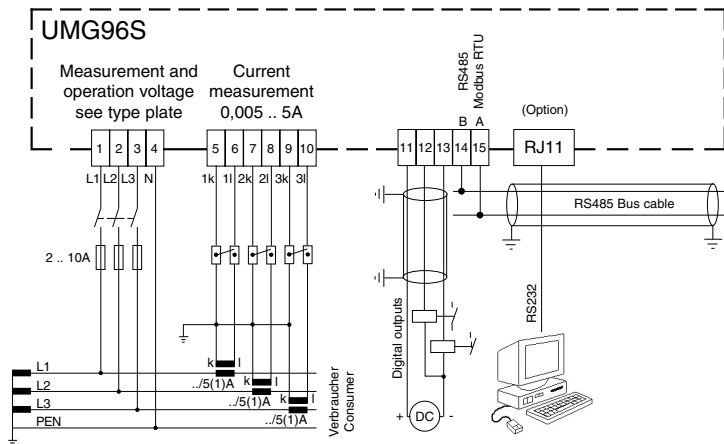

Diag. UMG96S with RS232 and digital outputs.

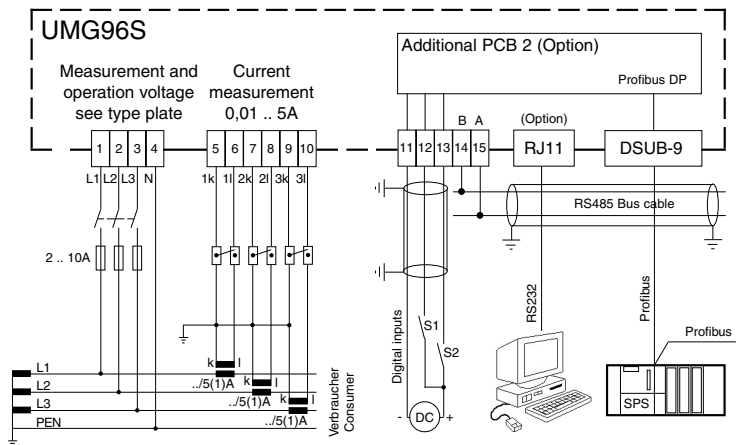

Diag. UMG96S with digital inputs, RS232 and Profibus.

Brief instructions

Change current transformer

Change into programming mode

If you are in indication mode and press key 1 and 2 simultaneously for about one second, you reach programming mode.

The symbol for programming mode **PRG** and current transformer **CT** appears.

Confirm selection with key 1.

The first number of the primary flashes.

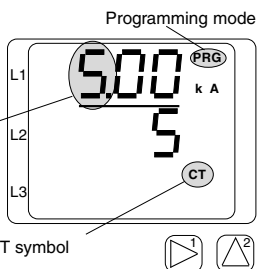

Change primary current

Change the flashing number with key 2.

Select next number using key 1.

The selected number flashes.

If the complete number is flashing, the decimal point can be moved.

Change secondary current

As secondary current, only 1A or 5A can be set.

Select secondary with key 1.

Change flashing number with key 2.

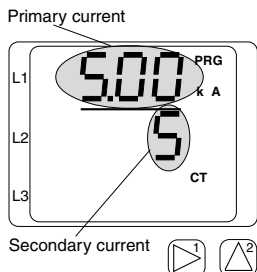

Leave programming mode

Press both keys for about 1 second.

The CT ratio is stored and you return to indication mode.

Call up measured values

Change into indication mode

If you are in programming mode and press key 1 and 2 simultaneously for about 1 second, you reach indication mode.

The symbol **PRG** is not on display and the first measured value display for voltage appears.

Key 2

With key 2 please scroll between the various measured value indications for current, voltage, power etc.

Key 1

Key 1 is used to scroll between the measured, mean values, maximum values etc. related to the measured value.

